

WATERLOO CITY COUNCIL

Regular Meeting Agenda

Date: July 15, 2019

Time: 7:30 p.m.

1. Call to Order.
2. Roll Call.
3. Pledge of Allegiance.
4. Correction or Withdrawal of Agenda Items by Sponsor.
5. Approval of Minutes as Written or Amended.
6. Petitions by Citizens on Non-Agenda Items.
7. Reports and Communications from the Mayor and other City Officers.
 - A. Report of Collector.
 - B. Report of Treasurer.
 - C. Report of Subdivision and Zoning Administrator.
 - D. Report of Building Inspector / Code Administrator.
 - E. Report of Director of Public Works.
 - F. Report of Chief of Police.
 - G. Report of City Attorney.
 - H. Report and Communication by Mayor.
 1. Commendation to Donovan McBride on his performance at the IHSA State Track & Field Meet.
 2. Commendation to Jenna Schwartz on her 5th place ranking at the IHSA State Track & Field Meet.
 3. Presentation of Awards for the Yards of Distinction Contest.
8. Report of Standing Committees.
9. Report of Special Committees.
10. Presentation of Communications, Petitions, Resolutions, Orders and Ordinances by Aldermen.
11. Unfinished Business.
12. Miscellaneous Business.
 - A. Consideration and Action on Approval of Improvement Plans for Country Club Hills PH III.
 - B. Consideration and Action on Purchase of an F150 Pickup Truck from Morrow Bros. Ford, in the amount of \$31,270.00, to replace a 1999 ¾ Ton Pickup Truck.
 - C. Consideration and Action on Approval of Visu-Sewer of Missouri, LLC as Low Bidder in the Amount of \$127,671.20 for the 2019 Sewer Lining Project.
 - D. Consideration and Action on Special Event Permit Application from Helping Strays of Monroe County for a Queen of Hearts Raffle to be conducted at Hopskeller Brewing Company on Thursday evenings beginning August 8, 2019.
 - E. Consideration and Action on Special Event Permit Application from JV's for the Annual Explore Waterloo event to be held on Friday, Sept. 13, 2019 from 6:00 p.m. to 11:00 p.m. with the closure of Main Street between First Street and the Flower Street alley.
 - F. Consideration and Action on Special Event Permit Application from Life Network of Southern Illinois for a Walk / Run / Ride to be held on September 21, 2019.
 - G. Consideration and Action on Special Event Permit Application from the WCUSD#5 for their Annual Bulldog Color Run to be held on September 28, 2019 with partial closures of Fourth, Rogers, First and Hamacher Streets.
 - H. Consideration and Action on Special Event Permit Application from LifechurchX for Biker Sunday to be held on September 29, 2019, from 7:00 a.m. to 3:00 p.m., with the closure of Main Street between Mill and Third Streets.
 - I. Consideration and Action on Special Event Permit Application from the SPPCS PTO for their Annual PumpkinFest 5K / 10K to be held on October 12, 2019 from 6:00 a.m. to 11:00 a.m.
 - J. Consideration and Action on Special Event Permit Application from the City of Waterloo for PumpkinFest to be held in Downtown Waterloo on October 12, 2019, from 7:30 a.m. to 5:00 p.m., with the closure of Main Street, Mill Street and Third Street around the Courthouse Square, and to include temporary signage.
13. Discussion of Matters by Council Members Arising After Agenda Deadline.
14. Motion to Adjourn.

DATES TO REMEMBER

July 17, 2019 – Police Pension Board Meeting, Waterloo City Hall: Front Conference Room, 5:30 p.m.
July 18, 2019 – Zoning Board of Appeals Meeting, Waterloo City Hall: Council Chambers, 7:30 p.m.
July 23, 2019 – American Legion Meeting, Waterloo City Hall: Second Floor, 7:00 p.m.
Aug. 05, 2019 – City Council Meeting, Waterloo City Hall: Council Chambers, 7:30 p.m.
Aug. 08, 2019 – Violence Prevention Meeting, Waterloo City Hall: Second Floor, 4:00 p.m.
Aug. 08, 2019 – Cemetery Board Meeting, Waterloo City Hall: Front Conference Room, 7:00 p.m.
Aug. 12, 2019 – Planning Commission Meeting, Waterloo City Hall: Council Chambers, 7:30 p.m.
Aug. 13, 2019 – Sister Cities Meeting, Waterloo City Hall: Front Conference Room, 7:00 p.m.
Aug. 14, 2019 – Park District Meeting, Waterloo City Hall: Front Conference Room, 7:00 p.m.
Aug. 15, 2019 – Zoning Board of Appeals Meeting, Waterloo City Hall: Council Chambers, 7:30 p.m.
Aug. 19, 2019 – City Council Meeting, Waterloo City Hall: Council Chambers, 7:30 p.m.
Aug. 27, 2019 – American Legion Meeting, Waterloo City Hall: Second Floor, 7:00 p.m.
Aug. 31 and Sept. 2, 2019 – City Offices Closed for the Labor Day Holiday.

**MINUTES OF THE
CITY COUNCIL MEETING
JULY 01, 2019**

1. The meeting was called to order by Mayor Smith at 7:30 p.m.
2. The following Aldermen were present: Notheisen, Thomas, Hopkins, Trantham, Darter, Buettner, Row and Heller.
3. Pledge of Allegiance led by Mayor Tom Smith.
4. Correction or Withdrawal of Agenda Items by Sponsor. None.
5. Approval of Minutes as Written or Amended.
Motion made by Alderman Darter and seconded by Alderman Hopkins to approve the June 17, 2019, 7:15 p.m., City Council Minutes. Motion passed unanimously with Aldermen Darter, Buettner, Row, Heller, Notheisen, Thomas, Hopkins and Trantham voting yea.
6. Petitions by Citizens on Non-Agenda Items.
Gerry Siekerka, 135 Links Lane, addressed the council regarding two issues he has with the Mystic Oak Golf Course adjacent to the back of his home: 1) spraying of Arbor Trees at his rear property line; and, 2) golfers relieving themselves in his yard. He will be meeting for a discussion with one of the Mystic Oak owners tomorrow and invited council members to join him. Alderman Notheisen advised Mr. Siekerka that more than one council member could not attend the meeting as it would violate the Open Meetings Act for elected officials.
7. Reports and Communications from the Mayor and other City Officers.
 - A. Report of Collector. None.
 - B. Report of Treasurer. None. Treasurer Papenberg was absent.
 - C. Report of Subdivision and Zoning Administrator.
This month the Planning Commission will consider a Zoning Map Amendment from Laurie Homes regarding property in the North Winds Subdivision.
 - D. Report of Director of Public Works. No report. Director Birk was absent.
 - E. Report of Deputy Chief of Police. None.
 - F. Report of City Attorney. None.
 - G. Report and Communication by Mayor.
 1. Commendation to the Gibault Boys Baseball Team – Commendation was presented and pictures taken.
8. Report of Standing Committees. None.
9. Report of Special Committees. None.
10. Presentation of Communications, Petitions, Resolutions, Orders and Ordinances by Aldermen.
 - A. Consideration and Action on Resolution No. 19-10 Approving an Annual TRANE Maintenance Contract in the amount of \$9,979.00.
Motion made by Alderman Buettner and seconded by Alderman Row to approve Resolution No. 19-10 approving an Annual TRANE Maintenance Contract in the amount of \$9,979.00. Motion passed unanimously with Aldermen Buettner, Row, Heller, Notheisen, Thomas, Hopkins, Trantham and Darter voting yea.

- B. Consideration and Action on Resolution No. 19-11 Authorizing the Execution of an Annual Agreement between the City of Waterloo, IL and MEGSI.
Motion made by Alderman Notheisen and seconded by Alderman Hopkins to approve Resolution No. 19-11 authorizing the execution of an Annual Agreement between the City of Waterloo, IL and MEGSI. Deputy Chief Prosis advised council that MEGSI is an acronym for Metropolitan Enforcement Group of Southern Illinois and they are a joint force tasked with drug investigations. Motion passed unanimously with Aldermen Notheisen, Thomas, Hopkins, Trantham, Darter, Buettner, Row and Darter voting yea.
- C. Consideration and Action on Resolution No. 19-12 Authorizing the Execution of a Memorandum of Understanding between the Waterloo Police Department and the Office of the Illinois Attorney General regarding the Illinois Internet Child Exploitation Task Force.
Motion made by Alderman Hopkins and seconded by Alderman Darter to approve Resolution No. 19-12 authorizing the execution of a Memorandum of Understanding between the Waterloo Police Department and the Office of the Illinois Attorney General regarding the Illinois Internet Child Exploitation Task Force. Mayor Smith advised council that Officer Meister needs the Memorandum of Understanding to officially handle our cases. Motion passed unanimously with Aldermen Hopkins, Trantham, Darter, Buettner, Row, Heller, Notheisen and Thomas voting yea.
- D. Consideration and Action on Ordinance No. 1785 Approving the Sale of Miscellaneous Equipment owned by the City of Waterloo, Illinois.
Motion made by Alderman Heller and seconded by Alderman Row to approve Ordinance No. 1785 approving the sale of miscellaneous equipment owned by the City of Waterloo, Illinois. It was noted there were quite a number of bids on the lawn mower. Motion passed unanimously with Aldermen Heller, Notheisen, Thomas, Hopkins, Trantham, Darter, Buettner and Row voting yea.
- E. Consideration and Action on Ordinance No. 1786 Authorizing the Purchase of Real Property (9.17) acres, for Placement of New Water Plant.
Motion made by Alderman Darter and seconded by Alderman Notheisen to approve Ordinance No. 1786 authorizing the purchase of real property (9.17) acres, for placement of the new Water Plant. Alderman Thomas asked if the city was required to wait until August 26th. Mayor Smith stated he would talk with Ron Kaiping to see if it could be done earlier. Motion passed unanimously with Aldermen Darter, Buettner, Row, Heller, Notheisen, Thomas, Hopkins and Trantham voting yea.
- F. Consideration and Action on Resolution No. 19-13 Authorizing a Letter of Support for the Monroe County Highway Department Application for Federal BUILD Grant Funds for Improvements to Bluff Road.
Motion made by Alderman Hopkins and seconded by Alderman Buettner to approve Resolution No. 19-13 authorizing a Letter of Support for the Monroe County Highway Department application for Federal BUILD grant funds for improvements to Bluff Road. Mayor Smith advised the section of Bluff Road to be improved was more than one mile in length. Motion passed unanimously with Aldermen Hopkins, Trantham, Darter, Buettner, Row, Heller, Notheisen and Thomas voting yea.
11. Unfinished Business. None.
12. Miscellaneous Business.
- A. Consideration and Action on Warrant No. 579.
Motion made by Alderman Darter and seconded by Alderman Notheisen to approve Warrant No. 579. Motion passed unanimously with Aldermen Darter, Buettner, Row, Heller, Notheisen, Thomas, Hopkins and Row voting yea.

- B. Consideration and Action on a Special Event Permit Application from the Optimist Club of Waterloo for their 17th Annual 5K Run / Fun Walk to be held on Saturday, August 24, 2019, between 8:00 a.m. and 9:30 a.m., and to include the closure of Rogers Street between First Street and Country Club Lane.
Motion made by Alderman Heller and seconded by Alderman Darter to approve a Special Event Permit Application from the Optimist Club of Waterloo for their 17th Annual 5K Run / Fun Walk to be held on Saturday, August 24, 2019, between 8:00 a.m. and 9:30 a.m., and to include the closure of Rogers Street between First Street and Country Club Lane. Deputy Chief Prosisie stated the Waterloo Police Department and the Sheriff's Department were okay with the event. Motion passed unanimously with Aldermen Heller, Notheisen, Thomas, Hopkins, Trantham, Darter, Buettner and Row voting yea.
- C. Consideration and Action on a Solicitation Request from the Waterloo Knights of Columbus to Conduct their Annual Tootsie Roll Fund Drive for Intellectual Disabilities on Friday and Saturday, September 20th and 21st, 2019 at the Intersections of Main / Mill and Rogers / Hamacher.
Motion made by Alderman Row and seconded by Alderman Thomas to approve a Solicitation Request from the Waterloo Knights of Columbus to conduct their Annual Tootsie Roll Fund Drive for Intellectual Disabilities on Friday and Saturday, September 20th and 21st, 2019 at the intersections of Main / Mill and Rogers / Hamacher. Motion passed unanimously with Aldermen Row, Heller, Notheisen, Thomas, Hopkins, Trantham, Darter and Buettner voting yea.
- D. Consideration and Action on Request from Human Support Services for Waiver of the Building Permit Fee (\$512.40) and the Building Inspection Fee (\$350.00) for an addition to be built at See More Inn, 4505 HH Road, in the total amount of \$862.40.
Motion made by Alderman Darter and seconded by Alderman Buettner to approve a request from Human Support Services for waiver of the building permit fee (\$512.40) and the building inspection fee (\$350.00) for an addition to be built at See More Inn, 4505 HH Road, in the total amount of \$862.40. Motion passed unanimously with Aldermen Darter, Buettner, Row, Heller, Notheisen, Thomas, Hopkins and Trantham voting yea.
- E. Consideration and Action on Approval of Preliminary Plat for Natalie Estates.
Motion made by Alderman Heller and seconded by Alderman Notheisen to approve the Preliminary Plat for Natalie Estates. Zoning Administrator, Jim Nagel stated the Planning Committee had recommended sidewalks for the subdivision and they were added by the developer. Motion passed unanimously with Aldermen Heller, Notheisen, Thomas, Hopkins, Trantham, Darter, Buettner and Row voting yea.
- F. Consideration and Action on Approval of Exterior Building Materials for R.P. Lumber at 942 South Market Street as allowed per the City of Waterloo, Illinois Revised Code of Ordinances, Chapter 6 Building Code, Section 6-1-2(1)(C).
Motion made by Alderman Trantham and seconded by Alderman Hopkins to approve the exterior building materials for R.P. Lumber at 942 South Market Street as allowed per the City of Waterloo, Illinois Revised Code of Ordinances, Chapter 6 Building Code, Section 6-1-2(1)(C). Motion passed unanimously with Aldermen Trantham, Darter, Buettner, Row, Heller, Notheisen, Thomas and Hopkins voting yea.
- G. Consideration and Action on terminating EAP Services with New Behavioral Directions Health and beginning EAP Services through Gateway Regional Medical Center effective July 1, 2019 through April 30, 2020.
Motion made by Alderman Thomas and seconded by Alderman Hopkins to approve terminating EAP Services with New Behavioral Directions Health and beginning EAP Services through Gateway Regional Medical Center effective July 1, 2019 through April 30, 2020. Motion passed unanimously with Aldermen Thomas, Hopkins, Trantham, Darter, Buettner, Row, Heller and Notheisen voting yea.

H. Consideration and Action on Executive Session for the Discussion of Personnel as per 5 ILCS 120/2(c)(1).

Motion made by Alderman Notheisen and seconded by Alderman Darter to approve Executive Session for the Discussion of Personnel as per 5 ILCS 120/2(c)(1). Motion passed unanimously with Aldermen Notheisen, Thomas, Hopkins, Trantham, Darter, Buettner, Row and Heller voting yea. Meeting recessed at 7:54 p.m.

Motion to reconvene made by Alderman Heller and seconded by Alderman Darter. Motion passed unanimously with Aldermen Heller, Notheisen, Thomas, Hopkins, Trantham, Darter, Buettner and Row voting yea. Meeting reconvened at 8:00 p.m.

13. Discussion of Matters by Council Members Arising After Agenda Deadline.

Alderman Notheisen stated that ten members of the Garden Club reviewed seven gorgeous yards for the Yard of Distinction and will be presenting the awards at the next City Council Meeting on July 15th. Alderman Notheisen additionally reminded everyone that Council will be handing out ice cream at the Band Concert tomorrow evening, July 2nd.

Alderman Hopkins stated that some people still think the swimming pool is a city function. Mayor Smith advised the city has done all it can to notify the public that a pool would be in the Park District. Alderman Darter stated the Park District was not interested. Alderman Notheisen asked about a Splash Park and Mayor Smith replied that Council will discuss a financial donation.

Alderman Buettner wished everyone a good Fourth of July.

Alderman Heller advised our two exchange students arrived in Germany on June 28th and will be returning on July 26th; which is coincidentally the same date the two exchange students from Germany will be arriving in Waterloo.

Mayor Smith stated next Tuesday, News Channel Two will be in town looking to put up a weather camera.

14. Motion to Adjourn made by Alderman Buettner and seconded by Alderman Notheisen. Motion passed with a unanimous voice vote. Mayor Smith adjourned the meeting at 8:05 p.m.

Tamara Kujawa,
DEPUTY CITY CLERK

**CITY OF WATERLOO, ILLINOIS
COLLECTION REPORT**

	2018-2019 ACTUAL AMOUNT	2019-2020 BUDGETED AMOUNT	% INCREASE/ DECREASE	2018 JUNE	2019 JUNE	% INCREASE/ DECREASE	2018-2019 FISCAL YTD	2019-2020 FISCAL YTD	% INCREASE/ DECREASE
ELEC SALES	11,486,100.40	11,475,000.00	-0.10%	749,381.38	703,689.67	-6.10%	1,500,740.50	1,448,108.69	-3.51%
ELEC TAX	284,075.14			18,330.18	18,004.78	-1.78%	36,332.91	37,114.04	2.15%
ELECT MISC.	321,562.00	270,400.00	-15.91%	18,896.00	43,691.00	131.22%	46,793.00	106,223.00	127.01%
SUBTOTAL	12,091,737.54	11,745,400.00	-2.86%	786,607.56	765,385.45	-2.70%	1,583,866.41	1,591,445.73	0.48%
BEGINNING UNAPPLIED	453,097.19			38,762.30	38,413.18	-0.90%	73,378.09	72,358.45	-1.39%
UNAPPLIED CASH REC'D	149,476.53			11,574.64	14,072.83	21.58%	20,814.18	24,272.16	16.61%
UNAPPLIED DISBURSED	150,147.05			6,244.22	5,593.83	-10.42%	11,337.25	11,325.25	-0.11%
ENDING UNAPPLIED	452,426.67			44,092.72	46,892.18	6.35%	82,855.02	85,305.36	2.96%
GAS SALES	2,947,323.95	2,872,000.00	-2.56%	210,999.42	177,338.35	-15.95%	517,434.05	506,438.05	-2.13%
GAS TAX	82,906.85			6,324.23	4,267.21	-32.53%	15,566.79	13,691.95	-12.04%
GAS MISC.	163,357.00	158,000.00	-3.28%	7,276.00	19,678.00	170.45%	22,686.00	49,937.00	120.12%
SUBTOTAL	3,193,587.80	3,030,000.00	-5.12%	224,599.65	201,283.56	-10.38%	555,686.84	570,067.00	2.59%
WATER SALES	2,386,304.02	2,515,000.00	5.39%	172,796.54	193,017.26	11.70%	349,155.26	384,150.86	10.02%
WATER MISC.	124,035.00	107,100.00	-13.65%	8,506.00	15,555.00	82.87%	19,015.00	35,772.00	88.13%
SUBTOTAL	2,510,339.02	2,622,100.00	4.45%	181,302.54	208,572.26	15.04%	368,170.26	419,922.86	14.06%
SEWER SALES	1,771,911.51	1,857,000.00	4.80%	131,120.03	144,368.49	10.10%	264,942.26	287,119.64	8.37%
SEWER MISC.	221,743.00	195,100.00	-12.02%	23,347.00	18,937.00	-18.89%	33,596.00	46,768.00	39.21%
SUBTOTAL	1,993,654.51	2,052,100.00	2.93%	154,467.03	163,305.49	5.72%	298,538.26	333,887.64	11.84%
CITY TAX	550,373.40	572,000.00	3.93%	37,009.94	36,219.24	-2.14%	79,004.59	80,919.82	2.42%
MISC.	89,041.00	72,500.00	-18.58%	2,377.00	11,294.00	375.14%	11,684.00	28,094.00	140.45%
SUBTOTAL	639,414.40	644,500.00	0.80%	39,386.94	47,513.24	20.63%	90,688.59	109,013.82	20.21%
REFUSE FEE	769,489.62	838,250.00	8.94%	62,009.09	65,541.97	5.70%	123,297.37	133,604.93	8.36%
VEHICLE STICKER	-	-		-	-		-	-	
FINES	48,962.00	50,000.00	2.12%	5,383.00	5,777.00	7.32%	8,984.00	10,316.00	14.83%
PERMITS	94,785.00	110,000.00	16.05%	12,673.00	5,055.00	-60.11%	16,591.00	12,179.00	-26.59%
INSPECTION FEES	17,750.00	20,000.00	12.68%	1,500.00	1,050.00	-30.00%	2,325.00	2,100.00	-9.68%
FRANCHISE FEES	126,510.00	127,000.00	0.39%	-	-		17,097.00	-	-100.00%
LIQUOR LICENSE	20,810.00	20,000.00	-3.89%	7,900.00	1,200.00	-84.81%	7,900.00	1,320.00	-83.29%
INFRASTRUCTURE FEE	230,006.00	230,000.00	0.00%	20,313.00	17,607.00	-13.32%	38,474.00	34,221.00	-11.05%
HOTEL/MOTEL TAX	19,655.00	20,000.00	1.76%	1,636.00	309.00	-81.11%	3,538.00	1,537.00	-56.56%
MISC.	227,908.00	213,315.00	-6.40%	11,809.00	19,664.00	66.52%	27,952.00	41,607.00	48.85%
REPLACEMENT TAX	53,844.00	56,400.00	4.75%	-	-		11,516.00	16,132.00	40.08%
COUNTY TAX	416,899.00	345,500.00	-17.13%	-	-		-	-	
SALES TAX	2,225,155.00	2,250,000.00	1.12%	182,342.00	193,396.00	6.06%	342,608.00	353,182.00	3.09%
BUSINESS DISTRICT TAX	88,899.00	80,000.00	-10.01%	6,417.00	7,098.00	10.61%	12,393.00	13,828.00	11.58%
VIDEO GAMING	117,079.00	122,000.00	4.20%	8,778.00	11,482.00	30.80%	18,375.00	25,185.00	37.06%
INCOME TAX	1,377,258.00	1,440,000.00	4.56%	94,621.00	98,049.00	3.62%	265,060.00	342,676.00	29.28%
SUBTOTAL	5,835,009.62	5,922,465.00	1.50%	415,381.09	426,228.97	2.61%	896,110.37	987,887.93	10.24%
MOTOR FUEL TAX	292,487.00	292,500.00	0.00%	22,917.00	22,058.00	-3.75%	47,810.00	46,127.00	-3.52%
MISC.	15,960.00	16,000.00	0.25%	1,037.00	1,470.00	41.76%	2,111.00	3,156.00	49.50%
SUBTOTAL	308,447.00	308,500.00	0.02%	23,954.00	23,528.00	-1.78%	49,921.00	49,283.00	-1.28%
UTILITY DEPOSITS	114,225.00	-		7,700.00	8,450.00	9.74%	15,850.00	19,950.00	25.87%
TOTAL DEPOSITS	26,835,891.42	26,325,065.00	-1.90%	1,844,973.45	1,858,339.80	0.72%	3,879,645.91	4,105,730.14	5.83%

July 15, 2019

To: Mayor Tom Smith
City Attorney
City Aldermen

Re: Treasurer's Report

Attached, please find the June 30, 2019 Treasurer's Report for the City of Waterloo.

I welcome any questions or comments you may have about this report. I can be reached at State Bank of Waterloo weekdays from 8:00 AM – 5:00 PM. The phone number is 618-939-7194.

Sincerely,

Brad A. Papenberg

Brad A Papenberg
City Treasurer

**TREASURER'S REPORT
CITY OF WATERLOO**

For the month ending
June 30, 2019

CHECKING ACCOUNT	BEGINNING BALANCE	RECEIPTS	DISBURSEMENTS	ENDING BALANCE
Petty Cash	\$ 497.98	\$ -	\$ -	\$ 497.98
Utility Deposit	66,502.52	8,450.00	9,325.00	65,627.52
General Fund	11,719.61	161,118.29	498,567.53	(325,729.63)
Motor Fuel Tax	87,021.23	46.73	39,097.62	47,970.34
Water Fund	148,025.39	200,007.42	161,890.42	186,142.39
Sewer Fund	606,668.59	158,223.62	96,040.70	668,851.51
Gas Fund	414,097.67	187,753.32	152,652.86	449,198.13
Electric Fund	1,080,416.62	753,490.81	781,044.71	1,052,862.72
Capital Improvements	623,278.15	38,367.15	-	661,645.30
D.A.R.E.	1,398.85	-	-	1,398.85
Interest	2,405.92	2,234.34	-	4,640.26
Hotel/Motel Tax	126,458.74	308.65	2,500.00	124,267.39
TOTALS:	\$3,168,491.27	\$1,510,000.33	\$1,741,118.84	\$2,937,372.76

INVESTED FUNDS

Capital Improvements	\$ 2,316,939.84	9,649.56	-	\$ 2,326,589.40
Electric	\$ 7,854,813.87	32,713.61	-	\$ 7,887,527.48
E-Pay Utility Bills	11,793.43	63,419.31	68,643.78	6,568.96
Farm Account Income	158,166.53	26.00	-	158,192.53
Gas	3,998,630.41	16,653.44	-	4,015,283.85
General Fund	6,669,532.13	340,736.03	-	7,010,268.16
Motor Fuel	723,307.91	23,481.28	-	746,789.19
Pension Reserve	1,693,492.30	347.98	-	1,693,840.28
Sewer	2,040,690.80	8,499.04	-	2,049,189.84
Utility Deposits	312,922.65	1,303.25	-	314,225.90
Water	2,415,338.46	10,059.37	-	2,425,397.83
Total Invested Funds:	\$28,195,628.33	\$506,888.87	\$68,643.78	\$28,633,873.42
Total All City Funds:	\$31,364,119.60	\$2,016,889.20	\$1,809,762.62	\$31,571,246.18

Debt and Pension Obligations	Date Opened	Original Balance	Current Balance	Rate	Payment Dates
IEPA Sewer Loan	5/24/2007	\$12,372,060.00	\$5,820,218.88	2.50%	Jan and July
Unfunded Actuarial Accrued Liability - IMRF			\$0.00		
Unfunded Actuarial Accrued Liability - Police			<u>\$3,900,765.00</u>		
Total Liabilities		\$12,372,060.00	\$9,720,983.88		

Respectfully Submitted,

Brad A. Papenberg

Brad A. Papenberg
City Treasurer

Building Inspector/Code Administrator Monthly Report 6/30/19

	January	February	March	April	May	June	July	August	September	October	November	December	Total
New Construction Inspections:													
2019	31	27	33	52	36	37							216
2018	20	30	33	45	42	57	41	45	27	45	23	27	435
2017	29	33	47	45	40	58	51	69	70	42	38	36	558
2016	12	14	23	30	49	26	44	21	42	35	20	23	339
2015	21	16	19	32	19	37	13	47	26	29	19	15	293
New Construction Re-Inspections:													
2019	4	3	6	4	8	6							31
2018	3	8	4	10	3	9	6	12	5	19	5	8	92
2017	8	5	6	11	4	9	5	7	9	8	5	7	84
Rental Inspections:													
2019	19	17	26	20	13	15							110
2018	17	12	16	15	10	26	14	31	19	21	23	10	214
2017	12	15	19	11	8	23	19	16	28	26	25	20	222
2016	21	15	12	18	26	23	26	23	20	22	17	16	239
Rental Re-Inspections:													
2019	12	14	15	13	8	12							74
2018	6	6	10	7	4	13	9	20	8	15	9	7	114
2017	9	8	13	1	8	13	14	9	17	11	13	14	130
Dumpster/POD Permits Issued:													
2019	8	9	15	18	25	10							85
2018	8	6	6	11	9	14	9	13	14	12	12	6	120
2017	9	7	13	16	10	13	13	9	13	6	9	5	123
2016	5	12	8	15	13	14	14	10	11	15	8	5	130
Motor Vehicle Violation Notices:													
2019	7	0	4	0	4	2							17
2018	9	6	2	3	2	2	1	2	0	1	7	3	38
2017	12	2	15	2	3	5	3	6	1	1	0	4	54
Property Violation Notices:													
2019	4	8	18	12	22	14							78
2018	14	14	9	19	26	14	10	20	5	8	20	8	167
2017	7	11	10	14	22	8	15	11	4	3	7	4	116
Ordinance Violation Tickets Issued:													
2019	0	1	3	1	1	3							9
2018	0	0	3	0	7	0	5	6	0	0	4	5	30
2017	1	0	5	1	3	1	4	2	3	7	3	1	31

AGENDA REQUEST

(Submit by 12:00 p.m. on Wednesday before the meeting date requested.)

1. Request is made for placement on the agenda for meeting to be held on:
July 15, 2019
(Date)
2. Description of matter to be placed on agenda:
Commendation to Donovan McBride on his performance at the IHSA State Track & Field Meet.

3. Relief or action to be requested:
Commendation.

4. Submittal date: 06/24/19

Submitted by: _____
Mayor Tom Smith

DISPOSITION

5. _____ Matter to be placed on agenda for meeting date requested.
_____ Matter to be placed on agenda for meeting to be held on _____
_____ Matter referred to _____



Mayor

AGENDA REQUEST

(Submit by 12:00 p.m. on Wednesday before the meeting date requested.)

1. Request is made for placement on the agenda for meeting to be held on:
July 15, 2019
(Date)

2. Description of matter to be placed on agenda:
Commendation to Jenna Schwartz on her 5th place ranking at the IHSA State Track & Field Meet.

3. Relief or action to be requested:
Commendation.

4. Submittal date: 06/24/19

Submitted by: _____
Mayor Tom Smith

DISPOSITION

5. _____ Matter to be placed on agenda for meeting date requested.
_____ Matter to be placed on agenda for meeting to be held on _____
_____ Matter referred to _____



Mayor

AGENDA REQUEST

(Submit by 12:00 p.m. on Wednesday before the meeting date requested.)

1. Request is made for placement on the agenda for meeting to be held on:
July 15, 2019
(Date)

2. Description of matter to be placed on agenda:
Presentation of Awards for the Yards of Distinction Contest.

3. Relief or action to be requested:
Presentation.

4. Submittal date: 06/24/19

Submitted by: _____
Alderman Steve Notheisen
_____ Waterloo Garden Club

DISPOSITION

5. _____ Matter to be placed on agenda for meeting date requested.
_____ Matter to be placed on agenda for meeting to be held on _____
_____ Matter referred to _____



Mayor

AGENDA REQUEST

(Submit by 12:00 p.m. on Wednesday before the meeting date requested.)

1. Request is made for placement on the agenda for meeting to be held on:
July 15, 2019
(Date)

2. Description of matter to be placed on agenda:
Consideration and Action on Approval of Improvement Plans for Country Club Hills PH III.

3. Relief or action to be requested:
Approval.

4. Submittal date: 06/28/19

Submitted by:
Jim Nagel, Subdivision & Zoning Administrator

DISPOSITION

5. Matter to be placed on agenda for meeting date requested.
 Matter to be placed on agenda for meeting to be held on
 Matter referred to



Mayor



CONSULTING ENGINEERING
GEOSPATIAL SERVICES

ILLINOIS | SWANSEA
WATERLOO
EDWARDSVILLE
PEORIA
MISSOURI | ST. CHARLES
ST. LOUIS
TENNESSEE | NASHVILLE

**THOUVENOT, WADE
& MOERCHEN, INC.**

SWANSEA OFFICE
4940 OLD COLLINSVILLE ROAD
SWANSEA, ILLINOIS
62226
(618) 624-4488
WWW.TWM-INC.COM

PROF. LICENSE	NUMBER
IL. PROF. DESIGN FIRM	184-001220
IL. PROF. ENGR. CORP.	62-035370
IL. PROF. STR. ENGR. CORP.	81-005202
IL. PROF. LAND SURV. CORP.	048-000029
MO. PROF. ENGR. CORP.	001528
MO. LAND SURVEYING CORP.	000346
TN. PROF. ENGR. FIRM	8974

SEAL

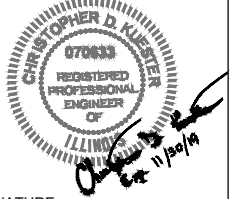

SIGNATURE:
DATE SIGNED: JUNE 17, 2019
LICENSE EXPIRATION: NOV. 30, 2019

IMPROVEMENT PLANS
JUNE 17, 2019

REV.	DATE	DESCRIPTION
1	6/17/2019	PER CITY REVIEW
2	6/17/2019	PER CITY REVIEW
3		
4		

DRAWN BY: LEM
DESIGNED BY: MJM
CHECKED BY: MJM
APPROVED BY: MJM
PROJECT NO: D01160158B

PROJECT:

COUNTRY CLUB HILLS PHASE III
CITY OF WATERLOO
MONROE COUNTY
ILLINOIS

TITLE:

COVER SHEET

INDEX OF SHEETS

- COVER SHEET
- GENERAL CONSTRUCTION NOTES
- EXISTING TOPOGRAPHY AND SITE PLAN
- SITE PLAN
- PLAN AND PROFILE - GLENBRIAR DRIVE
- PLAN AND PROFILE - SHERWOOD LANE & CASTLE GREEN DRIVE
- ROADWAY JOINT LOCATIONS AND ADA ACCESSIBILITY SPOT GRADING PLAN
- SANITARY SEWER PLAN AND PROFILE
- STORM SEWER PLAN
- STORM SEWER PROFILES
- STORM SEWER PROFILES
- GRADING AND EROSION CONTROL PLAN
- DETENTION OUTLET PLAN AND PROFILE
- WATERMAIN PLAN
- PAVEMENT DETAILS
- SANITARY SEWER DETAILS
- STORM SEWER DETAILS
- WATERMAIN DETAILS
- EROSION CONTROL DETAILS

**IMPROVEMENT PLANS FOR
COUNTRY CLUB HILLS PHASE III
CITY OF WATERLOO
MONROE COUNTY, ILLINOIS**

OWNER / DEVELOPER
SOUTHERN ILLINOIS DEVELOPMENT L.L.C.
301 AGNES DRIVE
O'FALLON IL, 62269
618-624-2111

CIVIL ENGINEER
THOUVENOT WADE & MOERCHEN, INC
113 SOUTH MAIN STREET
WATERLOO, ILLINOIS 62298
(618) 939-5050

LEGEND

=====	EXISTING STORM SEWER CULVERT	●	EXISTING WATER CURB STOP
=====	PROPOSED STORM SEWER CULVERT	○	PROPOSED WATER CURB STOP
----- FM -----	EXISTING SANITARY SEWER FORCEMAIN	⊗	EXISTING WATER VALVE
----- SAN -----	EXISTING SANITARY SEWER LINE	⊕	PROPOSED WATER VALVE
----- SAN -----	PROPOSED SANITARY SEWER LINE	⊙	EXISTING SANITARY SEWER MANHOLE
----- W -----	EXISTING WATER LINE	⊙	PROPOSED SANITARY SEWER MANHOLE
----- W -----	PROPOSED WATER LINE	⊗	EXISTING FIRE HYDRANT
=====	PROPERTY LINE	⊗	PROPOSED FIRE HYDRANT
=====	PROPOSED LOT LINE	●	STORM SEWER CURB INLET
-----	PROPOSED RIGHT-OF-WAY	○	STORM SEWER YARD/AREA INLET
-----	25' BUILDING SET BACK LINE (UNLESS OTHERWISE NOTED)		
-----	PROPOSED EASEMENT LINE		
~~~~~	TREE LINE		

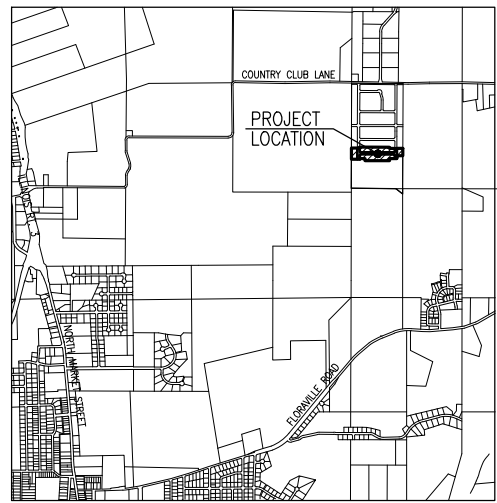

LOCATION MAP

**UTILITIES**

WATER:	CITY OF WATERLOO	618-939-8600
SANITARY SEWER:	CITY OF WATERLOO	618-939-8600
GAS & ELECTRIC:	CITY OF WATERLOO	618-939-8600
TELEPHONE:	HARRISONVILLE TELEPHONE COMPANY	618-939-6112
CABLE TV:	CHARTER CABLE	1-888-438-2427
J.U.L.I.E.:		1-800-892-0123

**CIVIL SITE ENGINEERING NOTES**

**GENERAL NOTES:**

PRIOR TO COMMENCEMENT OF ANY WORK, THE CONTRACTOR SHALL REVIEW ALL PLANS, SPECIFICATIONS, AND THE PROJECT SITE(S). THE CONTRACTOR SHALL BE RESPONSIBLE FOR NOTIFYING THE OWNER AND THE ENGINEER WHO PREPARED THE PLANS OF ANY DISCREPANCIES THAT MAY REQUIRE MODIFICATION TO THESE PLANS OR OF ANY FIELD CONFLICTS.

SHOULD IT APPEAR THAT THE WORK TO BE PERFORMED OR ANY MATTER RELATIVE THERETO IS NOT SUFFICIENTLY DETAILED OR EXPLAINED ON THESE PLANS, THE CONTRACTOR SHALL CONTACT THE ENGINEER FOR SUCH FURTHER EXPLANATIONS AS MAY BE NECESSARY.

THESE PLANS AND SPECIFICATIONS ARE SUBJECT TO MODIFICATIONS DURING CONSTRUCTION WHEN CONDITIONS DEVELOP THAT WERE NOT APPARENT DURING THE DESIGN AND PREPARATION OF THE PLANS AND SPECIFICATIONS. ALL MODIFICATIONS MUST BE APPROVED BY ALL PERTINENT AGENCIES HAVING JURISDICTION OVER THIS PROJECT PRIOR TO CONSTRUCTION AND/OR IMPLEMENTATION OF ANY PROPOSED CHANGES.

IN THE EVENT OF ANY DISCREPANCY BETWEEN ANY DRAWING AND THE FIGURES WRITTEN THEREON, THE FIGURES SHALL BE TAKEN AS CORRECT.

THE CONTRACTOR AGREES THAT IN ACCORDANCE WITH GENERALLY ACCEPTED CONSTRUCTION PRACTICES, THE CONTRACTOR WILL BE REQUIRED TO ASSUME SOLE AND COMPLETE RESPONSIBILITY FOR PROJECT SITE(S) CONDITIONS DURING THE COURSE OF CONSTRUCTION OF THE PROJECT, INCLUDING SAFETY OF ALL PERSONS AND PROPERTY. THIS REQUIREMENT SHALL BE MADE TO APPLY CONTINUOUSLY AND NOT BE LIMITED TO NORMAL WORKING HOURS. THE CONTRACTOR FURTHER AGREES TO DEFEND, INDEMNIFY, AND HOLD THE OWNER AND DESIGN PROFESSIONAL HARMLESS OF ANY AND ALL LIABILITY, REAL OR ALLEGED, IN CONNECTION WITH THE PERFORMANCE OF WORK ON THIS PROJECT.

TWM, INC. SHALL NOT BE RESPONSIBLE FOR OR HAVE CONTROL OVER CONSTRUCTION MEANS, METHODS, TECHNIQUES, SEQUENCES OR PROCEDURES IN CONNECTION WITH THE WORK.

ALL WORKMANSHIP, EQUIPMENT, MATERIALS, AND TESTING SHALL CONFORM TO THE PERTINENT MUNICIPAL, COUNTY, STATE, AND FEDERAL JURISDICTIONS AND AGENCIES HAVING AUTHORITY OVER THIS PROJECT. IN ADDITION, ALL WORKMANSHIP, EQUIPMENT, MATERIALS, AND TESTING SHALL CONFORM TO THE RESPECTIVE UTILITY COMPANY REQUIREMENTS. ALL EQUIPMENT, MATERIALS, AND PRODUCTS SHALL BE OF THE LATEST MANUFACTURE AND COMPLY WITH THE MOST UP TO DATE SPECIFICATIONS AT THE TIME OF BIDDING OF THE PROJECT.

CONTRACTOR SHALL BE SOLELY RESPONSIBLE FOR PROVIDING AND INSTALLING ANY AND ALL TRAFFIC BARRICADES, MARKERS, SIGNS, FLAGMEN, TRAFFIC POLICE, AND/OR OTHER FACILITIES AS MAY BE REQUIRED BY THE VARIOUS JURISDICTIONS HAVING AUTHORITY OVER THIS PROJECT TO PROTECT THE GENERAL PUBLIC. SIGNS AND PROTECTIVE DEVICES SHALL CONFORM TO THE MANUAL ON UNIFORM TRAFFIC CONTROL DEVICES FOR STREETS AND HIGHWAYS. THE CONTRACTOR SHALL HAVE THE RESPONSIBILITY OF NOTIFYING THE STATE AND LOCAL POLICE, EMERGENCY SERVICES AGENCIES, AMBULANCE SERVICES, AND FIRE DEPARTMENTS OF ANY PROPOSED TRAFFIC DIVERSION.

ALL UTILITIES INCLUDING BUT NOT LIMITED TO FIRE HYDRANTS, VALVE PIT COVERS, VALVE BOXES, CURB STOP BOXES, FIRE OR POLICE CALL BOXES, TRAFFIC CONTROL SIGNALS, OR OTHER UTILITY CONTROLS SHALL BE UNOBSTRUCTED AND ACCESSIBLE DURING THE CONSTRUCTION PERIOD.

WHERE SECTION OR SUBSECTION SURVEY MONUMENTS ARE ENCOUNTERED, THE CONTRACTOR SHALL PROTECT AND CAREFULLY PRESERVE ALL PROPERTY MARKERS AND MONUMENTS UNTIL THE OWNER AND AUTHORIZED SURVEYOR OR AGENT, HAVE WITNESSED OR OTHERWISE REFERENCED THEIR LOCATION.

ALL ITEMS NOTED FOR REMOVAL SHALL BE DISPOSED OF OFF-SITE BY THE CONTRACTOR IN COMPLIANCE WITH ALL LOCAL, STATE AND FEDERAL REGULATIONS.

IT SHALL BE THE RESPONSIBILITY OF THE CONTRACTOR TO REMOVE FROM THE SITE ANY AND ALL MATERIALS AND DEBRIS WHICH RESULT FROM HIS CONSTRUCTION OPERATIONS AT NO ADDITIONAL EXPENSE TO THE OWNER.

**UTILITY NOTES:**

THE TYPE, SIZE AND LOCATION OF UTILITIES AS DELINEATED ON THE PLANS AND SPECIFICATIONS HAVE BEEN DETERMINED BY REVIEW OF AVAILABLE EXISTING "AS-BUILT," OR "RECORD" DRAWINGS; FIELD SURVEY OF J.U.L.I.E. MARKED UTILITIES; OR FIELD SURVEY OF ABOVE GROUND SURFACE UTILITY FEATURES. THE OWNER AND ENGINEER HAVE NOT UNDERTAKEN SURFACE OR SUB-SURFACE EXPLORATORY INVESTIGATIONS TO CONFIRM OR VERIFY THE LOCATION OF UTILITIES ON THE PROJECT SITE. THEREFORE ALL UTILITY LOCATIONS, SIZE, AND FUNCTION MUST BE CONSIDERED APPROXIMATE AND THE CONTRACTOR MUST VERIFY ALL UTILITIES IN THE FIELD.

THE ENGINEER AND OWNER FURTHER DO NOT WARRANT THAT ALL UTILITIES HAVE BEEN ILLUSTRATED ON THE PLANS. THE CONTRACTOR IS SOLELY RESPONSIBLE FOR CONTACTING J.U.L.I.E. AND/OR THE PERTINENT UTILITY FOR FIELD VERIFICATION OF ALL UTILITIES ON THE SITE PRIOR TO THE COMMENCEMENT OF ANY CONSTRUCTION OPERATIONS. IF THE CONTRACTOR DETERMINES THAT SUBSTANTIAL DISCREPANCY EXISTS BETWEEN FIELD VERIFIED UTILITIES AND THESE PLANS WHICH WOULD SIGNIFICANTLY AFFECT THE FUNCTION, COST, OR PERFORMANCE OF THE PROJECT, THE CONTRACTOR SHALL IMMEDIATELY CONTACT THE ENGINEER FOR CLARIFICATION AND PROJECT DESIGN COORDINATION.

ANY RELOCATION OF PUBLIC OR PRIVATE UTILITIES SHALL BE UNDERTAKEN IN ACCORDANCE WITH ALL REQUIREMENTS OF THE UTILITY COMPANY AND WITH REGARD TO THE REQUIRED FEES, BONDS, PERMITS, AGREEMENTS, WORKING CONDITIONS, ETC. OF SAID COMPANY OR JURISDICTION. THE CONTRACTOR SHALL NOTIFY ALL UTILITY COMPANIES AND JURISDICTIONS A MINIMUM OF FORTY-EIGHT (48) HOURS PRIOR TO COMMENCEMENT OF WORK TO ALLOW THE UTILITIES TO MARK THEIR LINES OR TO ALLOW THE PERTINENT JURISDICTIONS TIME TO COORDINATE THEIR STAFF, MATERIALS, AND EQUIPMENT TO CONDUCT INSPECTION.

THE CONTRACTOR SHALL BE HELD RESPONSIBLE FOR ANY AND ALL DAMAGE TO EXISTING STRUCTURES, AND/OR UTILITIES DURING CONSTRUCTION. THE CONTRACTOR SHALL CONTACT THE APPROPRIATE UTILITY OR JURISDICTION TO PROPERLY REPAIR ANY FACILITIES DAMAGED IN THE COURSE OF THE WORK.

ALL ABANDONED UNDERGROUND STRUCTURES ENCOUNTERED SHALL BE REMOVED TO SUFFICIENT DEPTH TO ALLOW UNDERGROUND UTILITIES TO CROSS.

ALL PROPOSED ELECTRIC TRANSFORMERS AND STREETLIGHTS SHALL BE INSTALLED BY OTHERS.

UTILITIES AND APPURTENANCES TO REMAIN IN THEIR PRESENT LOCATION SHALL BE ADJUSTED TO GRADE. CONTRACTOR SHALL TAKE ALL REASONABLE PRECAUTIONS TO PROTECT EXISTING UTILITIES.

**GENERAL SPECIFICATIONS:**

ALL WORK, INSTALLATION, PROCEDURES, MATERIALS, AND TESTING ASSOCIATED WITH THIS PROJECT SHALL CONFORM TO THE FOLLOWING STANDARDS:

- STANDARD SPECIFICATIONS FOR WATER AND SEWER MAIN CONSTRUCTION IN ILLINOIS, FIFTH EDITION
- ILLINOIS RECOMMENDED STANDARDS FOR SEWAGE WORKS, 1997 EDITION AS PUBLISHED BY THE ILLINOIS EPA.
- RECOMMENDED STANDARDS FOR WATER WORKS, 1997 EDITION
- STANDARD SPECIFICATIONS FOR ROAD AND BRIDGE CONSTRUCTION, AS PUBLISHED BY THE ILLINOIS DEPARTMENT OF TRANSPORTATION, ADOPTED APRIL 1, 2016; AND THE SUPPLEMENTAL SPECIFICATIONS AND RECURRING SPECIAL PROVISIONS ADOPTED APRIL 1, 2016.
- STANDARDS AND SPECIFICATIONS FOR SOIL EROSION AND SEDIMENT CONTROL, 1987 EDITION, AS PUBLISHED BY THE ILLINOIS ENVIRONMENTAL PROTECTION AGENCY
- 77 ILLINOIS ADMINISTRATIVE CODE, PART 890, ILLINOIS PLUMBING CODE
- ILLINOIS URBAN MANUAL, 1995 EDITION AS PUBLISHED BY THE ILLINOIS EPA
- UNITED STATES AMERICANS WITH DISABILITIES ACT, AND THE ILLINOIS ADA
- ALL ORDINANCES, LAWS, REGULATIONS, AND STANDARDS OF ALL PERTINENT AUTHORITIES HAVING JURISDICTION OVER THE WORK ASSOCIATED WITH THIS PROJECT.

IF ANY INCONSISTENCIES, DISCREPANCIES, OR CONFLICTS ARE DISCOVERED BETWEEN THE VARIOUS STANDARDS, SPECIFICATIONS, OR LAWS BY GOVERNING AUTHORITIES, AND /OR THESE PLANS AND SPECIFICATIONS, THE MOST STRINGENT STANDARD, SPECIFICATION LAW AND/OR STANDARD SHALL BE BINDING AND APPLICABLE TO THIS PROJECT.

ONLY THOSE DIMENSIONS SHOWN ON THE DRAWINGS SHALL BE USED FOR DETERMINATION OF LOCATION AND SIZES OF PROPOSED IMPROVEMENTS. DO NOT SCALE DRAWINGS. IF ANY DISCREPANCIES ARE DISCOVERED ON THE PLANS OR BETWEEN THE PLANS AND THE SPECIFICATIONS, THE CONTRACTOR SHALL NOTIFY THE ENGINEER AND OBTAIN CLARIFICATION OF THE INTENT FROM THE ENGINEER PRIOR TO CONSTRUCTION OR INSTALLATION OF PROPOSED IMPROVEMENTS.

ALL WORK, MATERIALS, AND INSTALLATION SHALL NOT BE DEEMED SATISFACTORY UNTIL SUCH TIME AS ALL APPROVALS ARE OBTAINED FROM THE MUNICIPALITY OR ENTITY HAVING JURISDICTION OVER THE PROJECT.

THE CONTRACTOR SHALL PROCEED AT HIS OWN RISK IN PERFORMING ANY WORK PRIOR TO VERIFYING OR RECEIVING ALL NECESSARY PERMITS FOR THE WORK TO BE DONE.

**TITLE INFORMATION:**

IT IS NOT WARRANTED THAT THESE PLANS CONTAIN COMPLETE INFORMATION REGARDING EASEMENTS, RESERVATIONS, RESTRICTIONS, RIGHTS-OF-WAY, BUILDING LINE SETBACKS, AND OTHER ENCUMBRANCES. FOR COMPLETE INFORMATION, A TITLE OPINION OR COMMITMENT FOR TITLE INSURANCE SHOULD BE OBTAINED AND THOROUGHLY REVIEWED TO ASSESS THE IMPACT OF RESTRICTIONS AND ENCUMBRANCES ASSOCIATED WITH THE SITE.





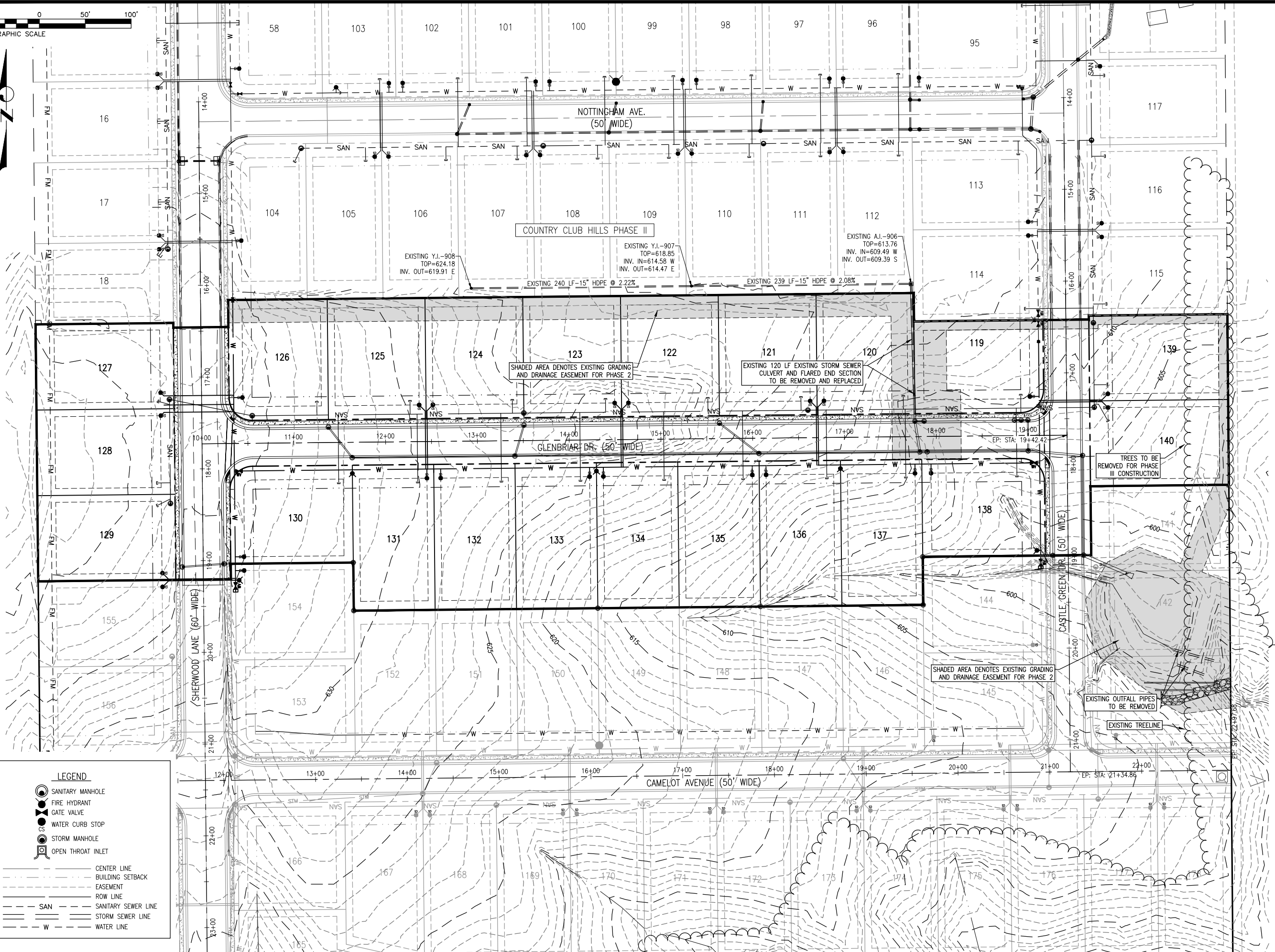

**LEGEND**

	SANITARY MANHOLE
	FIRE HYDRANT
	GATE VALVE
	WATER CURB STOP
	STORM MANHOLE
	OPEN THROAT INLET
	CENTER LINE
	BUILDING SETBACK
	EASEMENT
	ROW LINE
	SANITARY SEWER LINE
	STORM SEWER LINE
	WATER LINE



CONSULTING ENGINEERING  
GEOSPATIAL SERVICES

ILLINOIS SWANSEA  
WATERLOO  
EDWARDSVILLE  
PEORIA

MISSOURI ST. CHARLES  
ST. LOUIS

TENNESSEE | NASHVILLE

**THOUVENOT, WADE  
& MOERCHEN, INC.**

SWANSEA OFFICE  
4940 OLD COLLINSVILLE ROAD  
SWANSEA, ILLINOIS  
62226  
(618) 624-4488  
WWW.TWM-INC.COM

PROF. LICENSE	NUMBER
IL PROF. DESIGN FIRM	184-001220
IL PROF. ENGR. CORP.	62-035370
IL PROF. STR. ENGR. CORP.	81-005202
IL PROF. LAND SURV. CORP.	048-000029
MO. PROF. ENGR. CORP.	001528
MO. LAND SURVEYING CORP.	000346
TN. PROF. ENGR. FIRM	8974

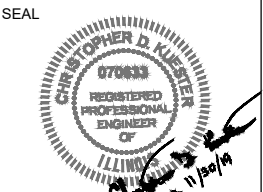

SIGNATURE:  
DATE SIGNED: JUNE 17, 2019  
LICENSE EXPIRATION: NOV. 30, 2019

IMPROVEMENT PLANS  
JUNE 17, 2019

REV.	DATE	DESCRIPTION
△		
△		
△		
△		

DRAWN BY: LEM  
DESIGNED BY: LEM  
CHECKED BY: MJM  
APPROVED BY: MJM  
PROJECT NO: D01160158B

PROJECT:  
COUNTRY CLUB HILLS PHASE III  
CITY OF WATERLOO  
MONROE COUNTY  
ILLINOIS

TITLE:  
EXISTING TOPOGRAPHY  
AND SITE PLAN

P:\160158B\160158B-PLANS-PHASE 3.dwg Plotted By: dkleister

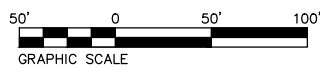

CONSULTING ENGINEERING  
GEOSPATIAL SERVICES

ILLINOIS SWANSEA  
WATERLOO  
EDWARDSVILLE  
PEORIA

MISSOURI ST. CHARLES  
ST. LOUIS

TENNESSEE | NASHVILLE

**THOUVENOT, WADE  
& MOERCHEN, INC.**

SWANSEA OFFICE  
4940 OLD COLLINSVILLE ROAD  
SWANSEA, ILLINOIS  
62226  
(618) 624-4488  
WWW.TWM-INC.COM

PROF. LICENSE	NUMBER
IL PROF. DESIGN FIRM	184-001220
IL PROF. ENGR. CORP.	62-035370
IL PROF. STR. ENGR. CORP.	81-005202
IL PROF. LAND SURV. CORP.	048-000029
MO. PROF. ENGR. CORP.	001528
MO. LAND SURVEYING CORP.	000346
TN. PROF. ENGR. FIRM	8974

SEAL

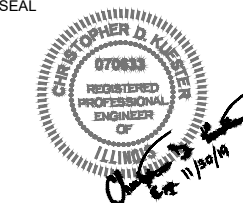

SIGNATURE:  
DATE SIGNED: JUNE 17, 2019  
LICENSE EXPIRATION: NOV. 30, 2019

IMPROVEMENT PLANS  
JUNE 17, 2019

REV.	DATE	DESCRIPTION
△		
△		
△		
△		

DRAWN BY: LEM  
DESIGNED BY:  
CHECKED BY: MJM  
APPROVED BY: MJM  
PROJECT NO: D01160158B

PROJECT:  
  
COUNTRY CLUB HILLS PHASE III  
CITY OF WATERLOO  
MONROE COUNTY  
ILLINOIS

TITLE:  
  
SITE PLAN

P:\160158B\160158B-PLANS-PHASE 3.dwg Plotted By: ckleister

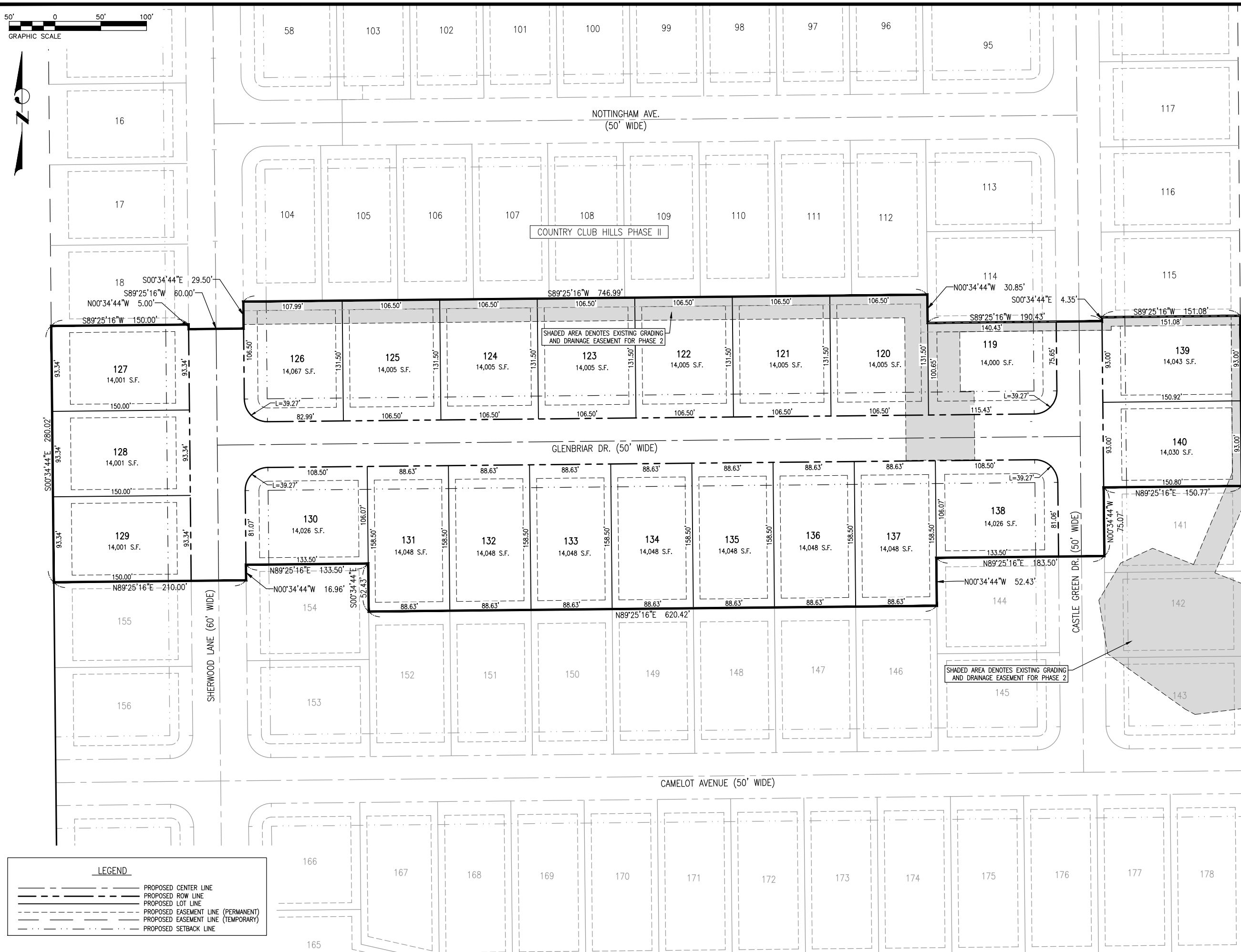

**LEGEND**

- PROPOSED CENTER LINE
- - - PROPOSED ROW LINE
- PROPOSED LOT LINE
- - - PROPOSED EASEMENT LINE (PERMANENT)
- - - PROPOSED EASEMENT LINE (TEMPORARY)
- - - PROPOSED SETBACK LINE



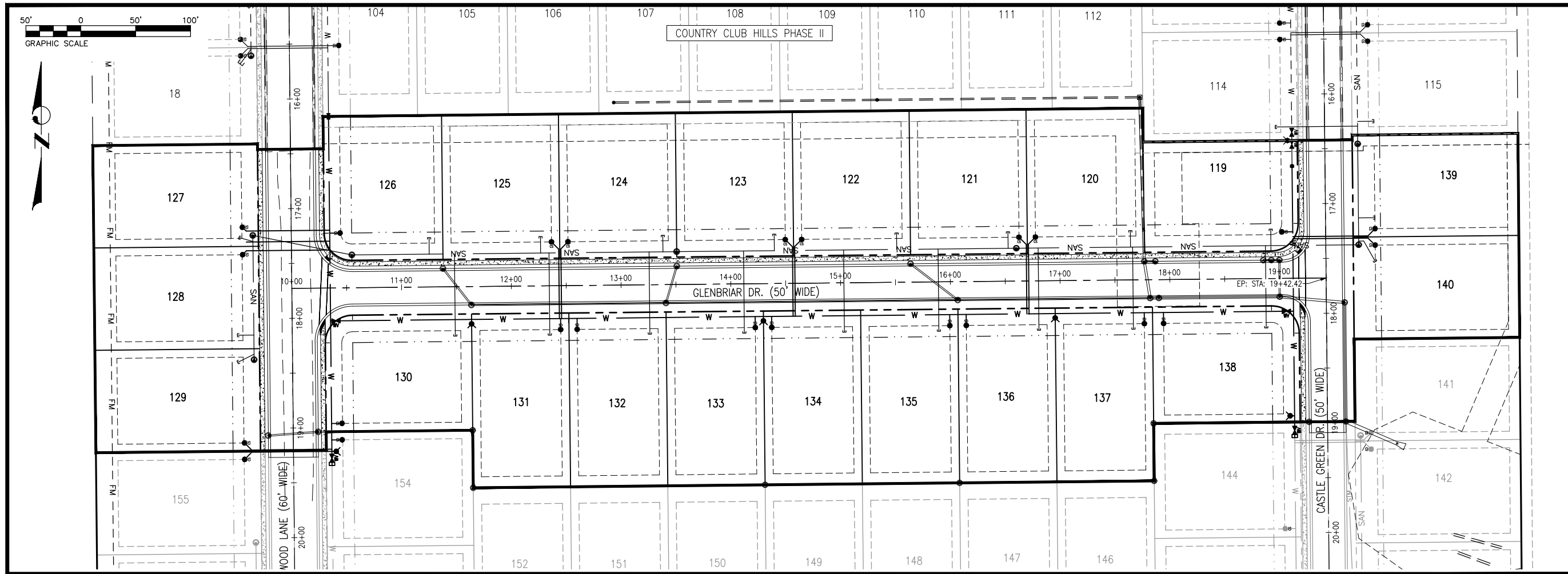

**TWM**  
 CONSULTING ENGINEERING  
 GEOSPATIAL SERVICES

ILLINOIS SWANSEA  
 WATERLOO  
 EDWARDSVILLE  
 PEORIA

MISSOURI ST. CHARLES  
 ST. LOUIS

TENNESSEE | NASHVILLE

**THOUVENOT, WADE & MOERCHEN, INC.**

SWANSEA OFFICE  
 4940 OLD COLLINSVILLE ROAD  
 SWANSEA, ILLINOIS  
 62226  
 (618) 624-4488  
 WWW.TWM-INC.COM

PROF. LICENSE	NUMBER
IL PROF. DESIGN FIRM	184-001220
IL PROF. ENGR. CORP.	62-035370
IL PROF. STR. ENGR. CORP.	81-005202
IL PROF. LAND SURV. CORP.	048-000029
MO. PROF. ENGR. CORP.	001528
MO. LAND SURVEYING CORP.	000346
TN. PROF. ENGR. FIRM	8974

SEAL

SIGNATURE:  
 DATE SIGNED: JUNE 17, 2019  
 LICENSE EXPIRATION: NOV. 30, 2019

IMPROVEMENT PLANS  
 JUNE 17, 2019

REV.	DATE	DESCRIPTION
△	6/7/2019	PER CITY REVIEW
△		
△		

DRAWN BY: LEM  
 DESIGNED BY:  
 CHECKED BY: MJM  
 APPROVED BY: MJM  
 PROJECT NO: D01160158B

PROJECT:  
 COUNTRY CLUB HILLS PHASE III  
 CITY OF WATERLOO  
 MONROE COUNTY  
 ILLINOIS

TITLE:  
 PLAN AND PROFILE  
 GLENBRIAR DRIVE

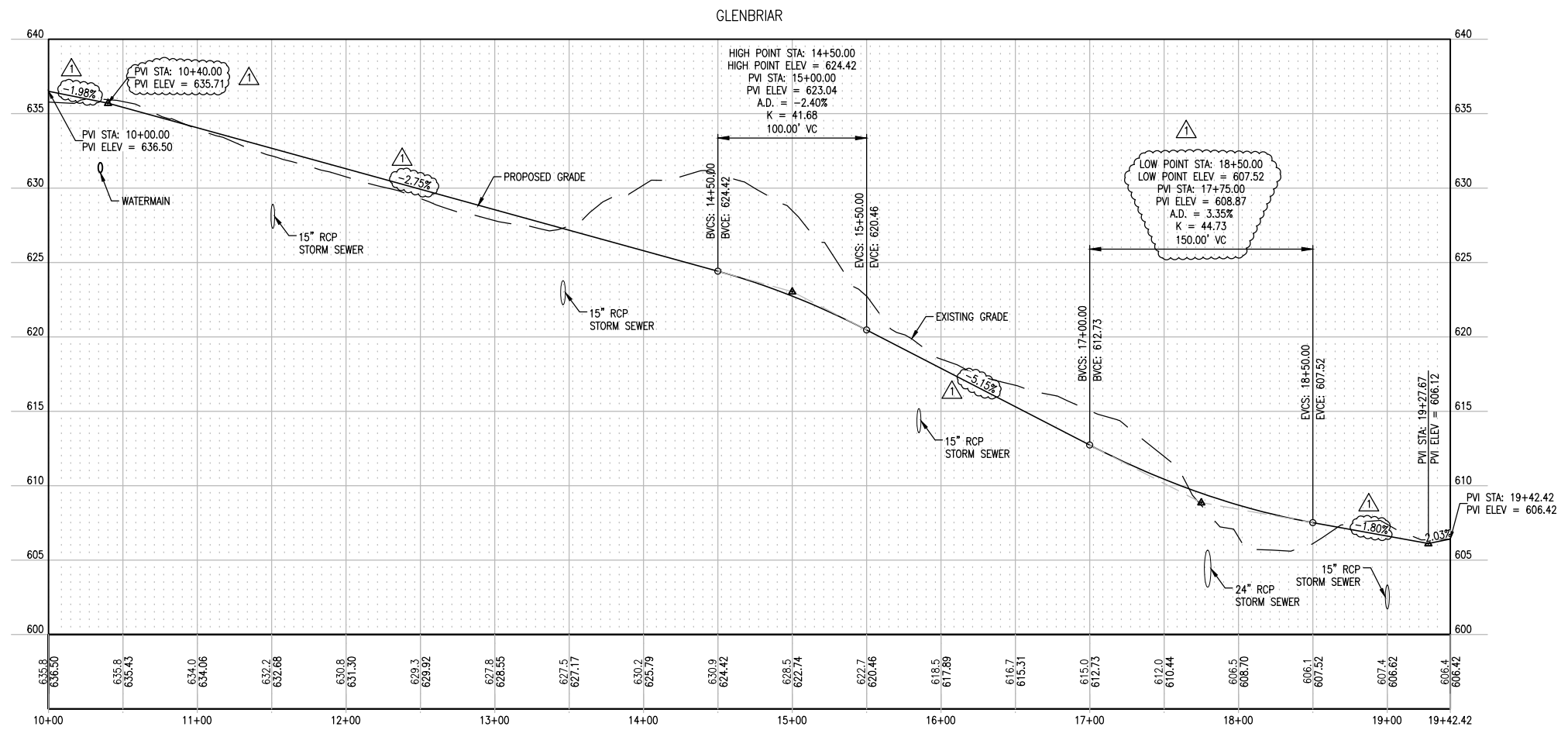

P:\160158B\160158B-CADD - DWG\4-5 Sub\160158B-PLANS-PHASE 3.dwg Plotted By: cluester

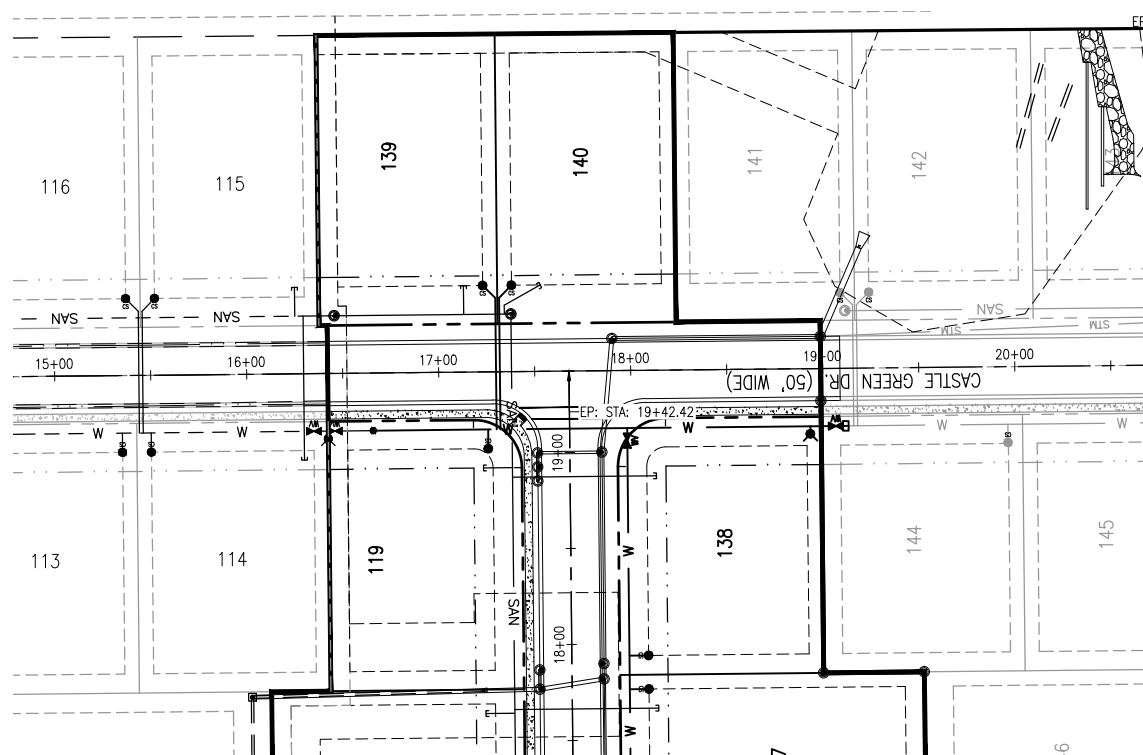
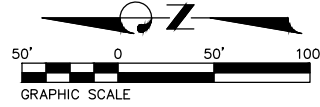
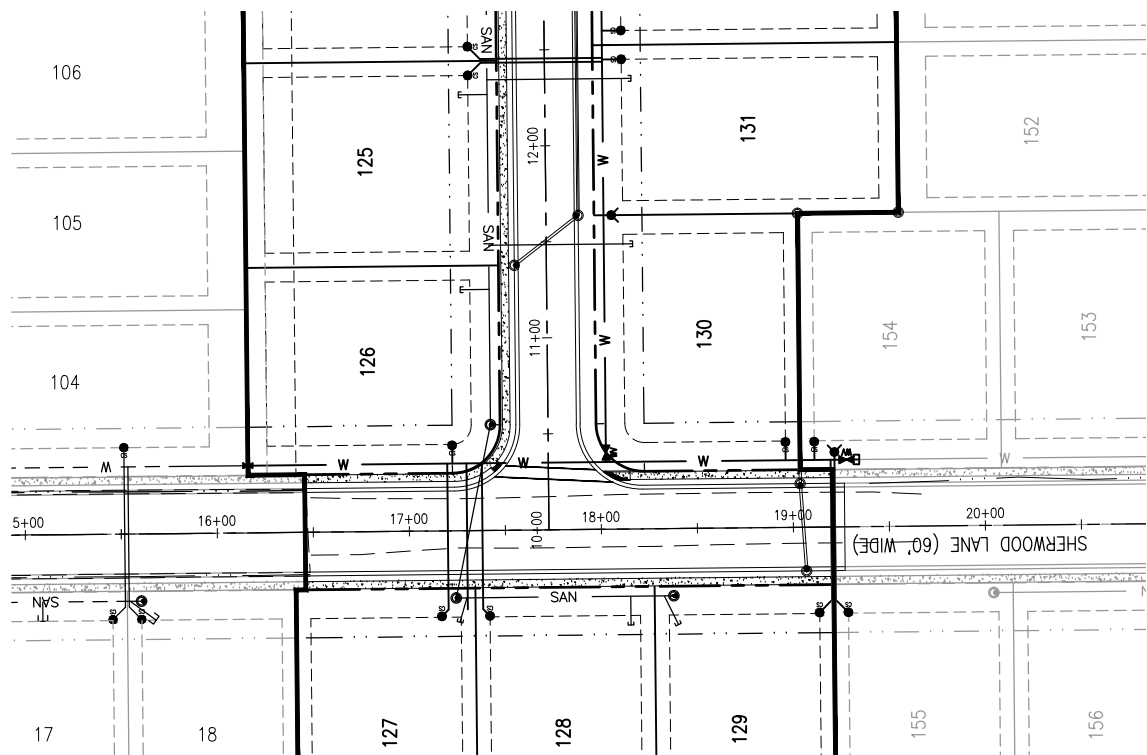
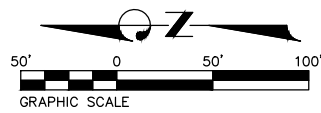

SHERWOOD

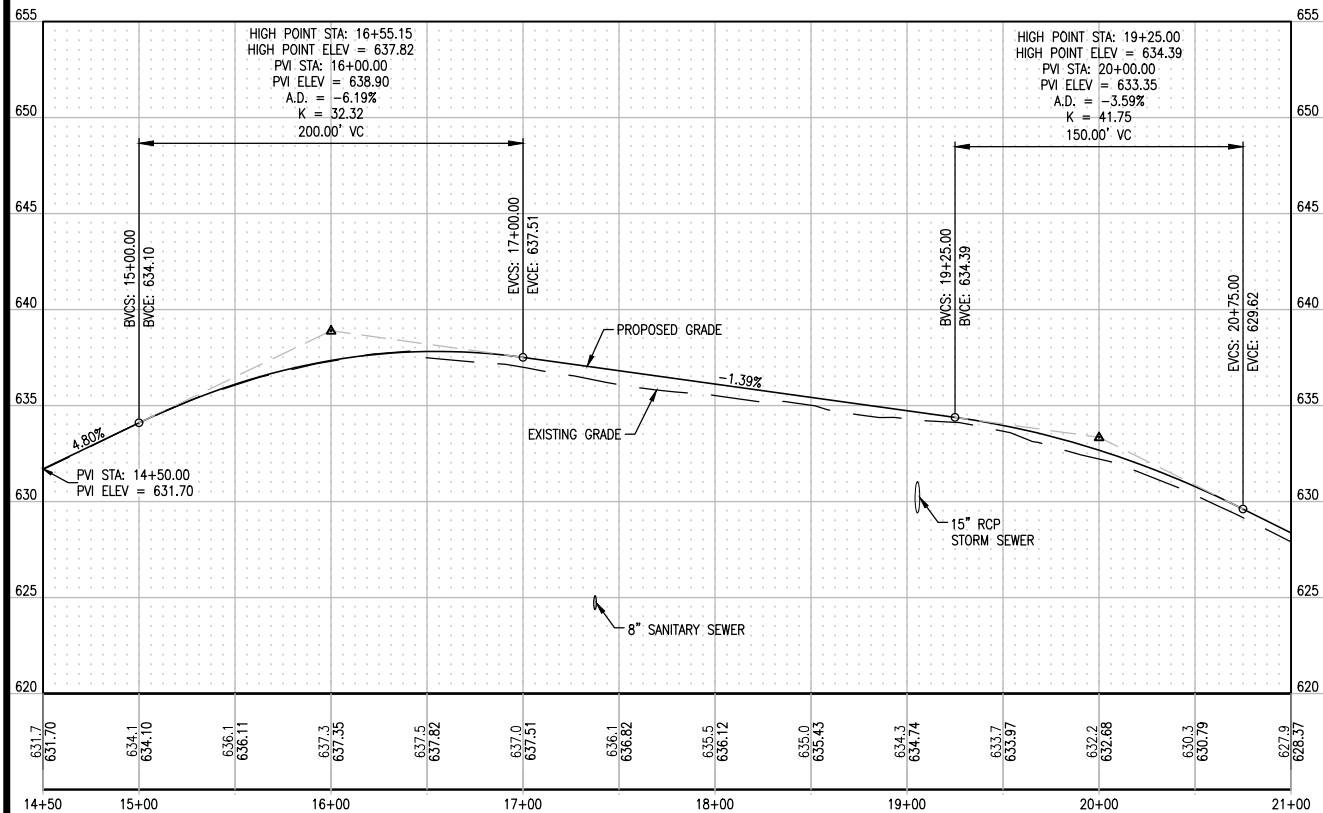

CASTLE GREEN

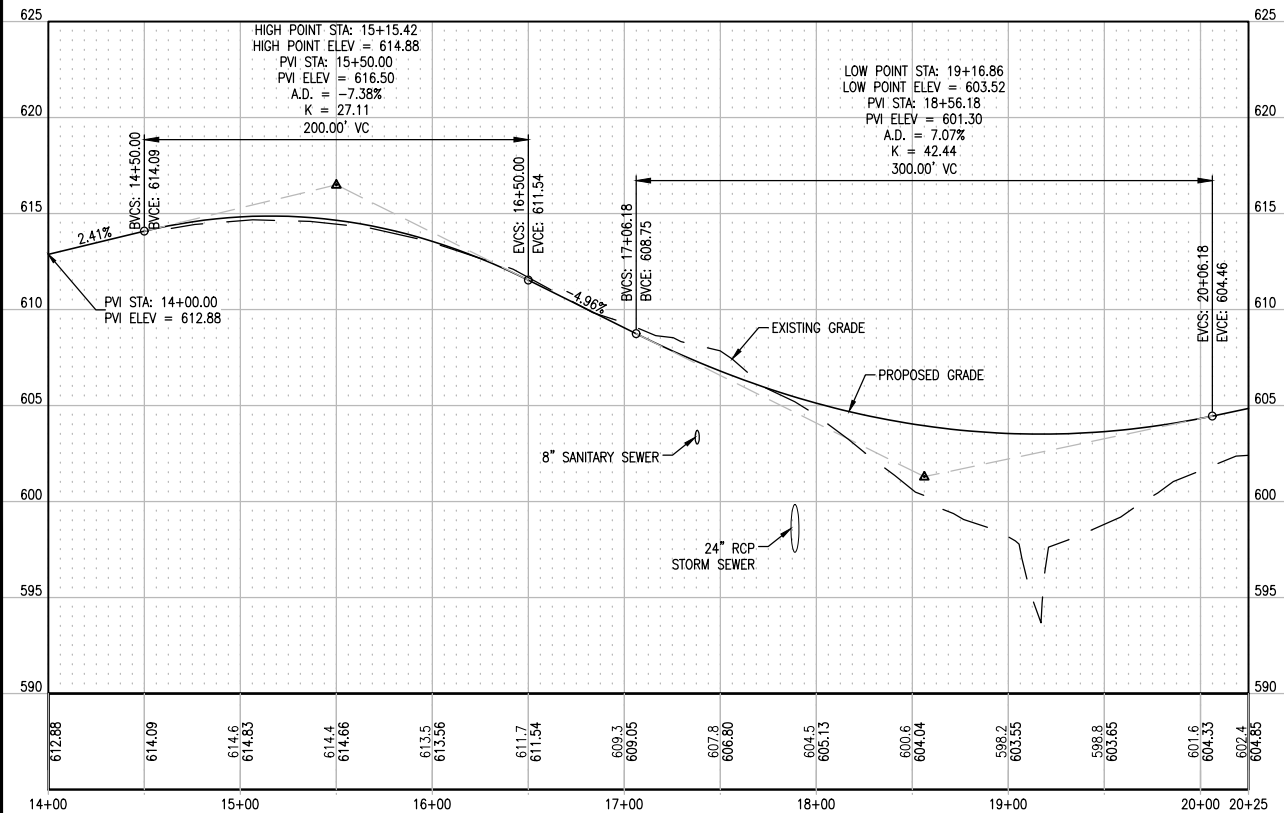

P:\1601588\1601588-PLANS-PHASE 3.dwg Plotted By: chuester



CONSULTING ENGINEERING  
GEOSPATIAL SERVICES

ILLINOIS SWANSEA  
WATERLOO  
EDWARDSVILLE  
PEORIA  
MISSOURI ST. CHARLES  
ST. LOUIS  
TENNESSEE | NASHVILLE

**THOUVENOT, WADE  
& MOERCHEN, INC.**

SWANSEA OFFICE  
4940 OLD COLLINSVILLE ROAD  
SWANSEA, ILLINOIS  
62226  
(618) 624-4488  
WWW.TWM-INC.COM

PROF. LICENSE	NUMBER
IL PROF. DESIGN FIRM	184-001220
IL PROF. ENGR. CORP.	62-035370
IL PROF. STR. ENGR. CORP.	81-005202
IL PROF. LAND SURV. CORP.	048-000029
MO. PROF. ENGR. CORP.	001528
MO. LAND SURVEYING CORP.	000346
TN. PROF. ENGR. FIRM	8974

SEAL

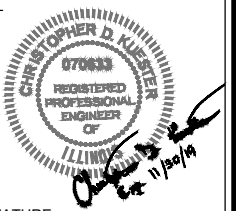

SIGNATURE:  
DATE SIGNED: JUNE 17, 2019  
LICENSE EXPIRATION: NOV. 30, 2019

IMPROVEMENT PLANS  
JUNE 17, 2019

REV.	DATE	DESCRIPTION
△		
△		
△		
△		

DRAWN BY: LEM  
DESIGNED BY: LEM  
CHECKED BY: MJM  
APPROVED BY: MJM  
PROJECT NO: D01160158B

PROJECT:  
COUNTRY CLUB HILLS PHASE III  
CITY OF WATERLOO  
MONROE COUNTY  
ILLINOIS

TITLE:  
PLAN AND PROFILES  
SHERWOOD LANE &  
CASTLE GREEN DRIVE

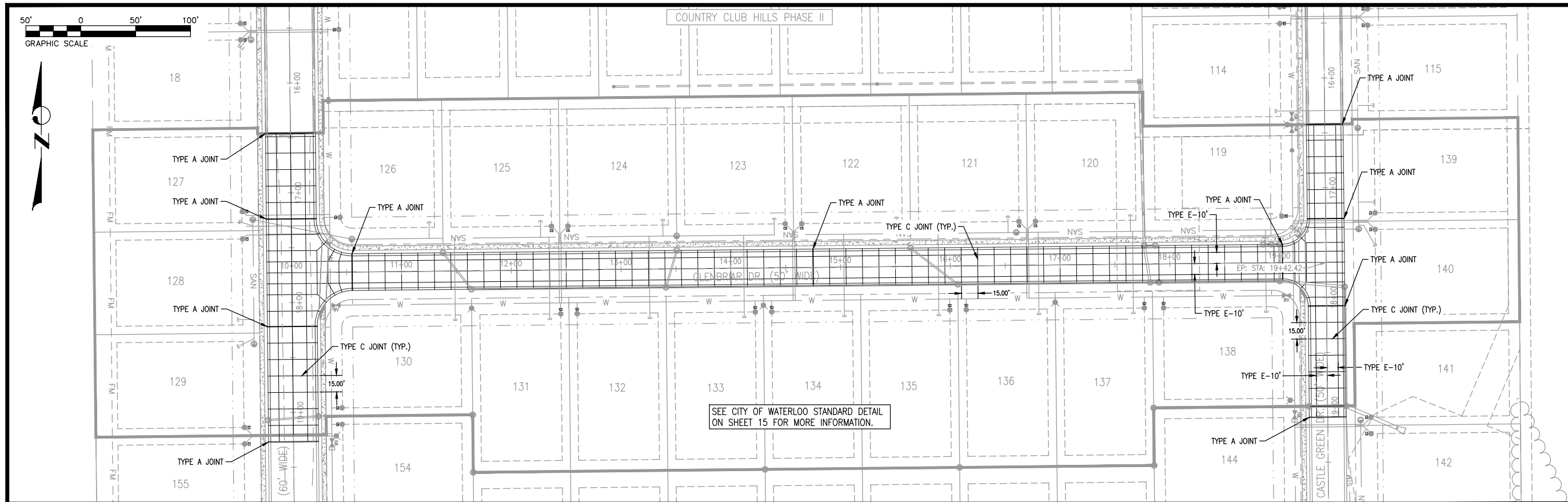

SEE CITY OF WATERLOO STANDARD DETAIL ON SHEET 15 FOR MORE INFORMATION.

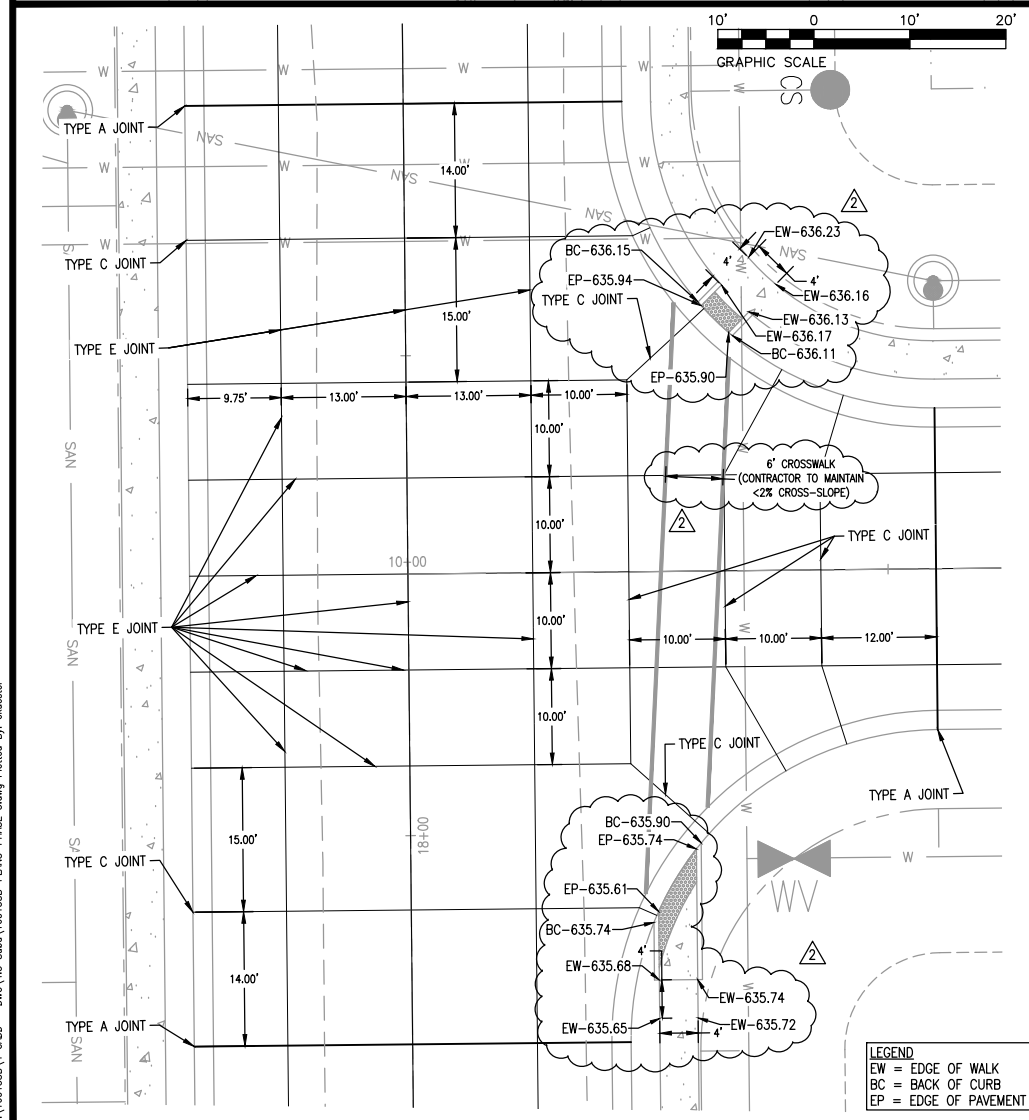

LEGEND  
 EW = EDGE OF WALK  
 BC = BACK OF CURB  
 EP = EDGE OF PAVEMENT

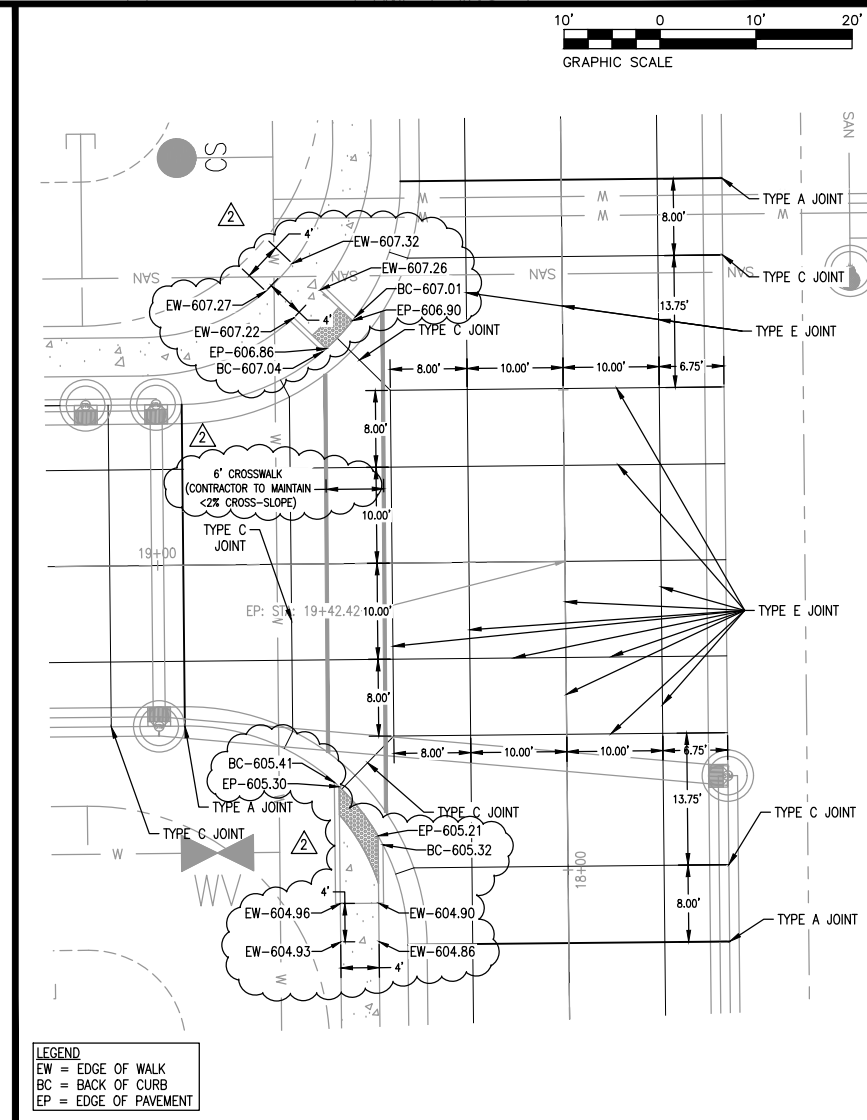
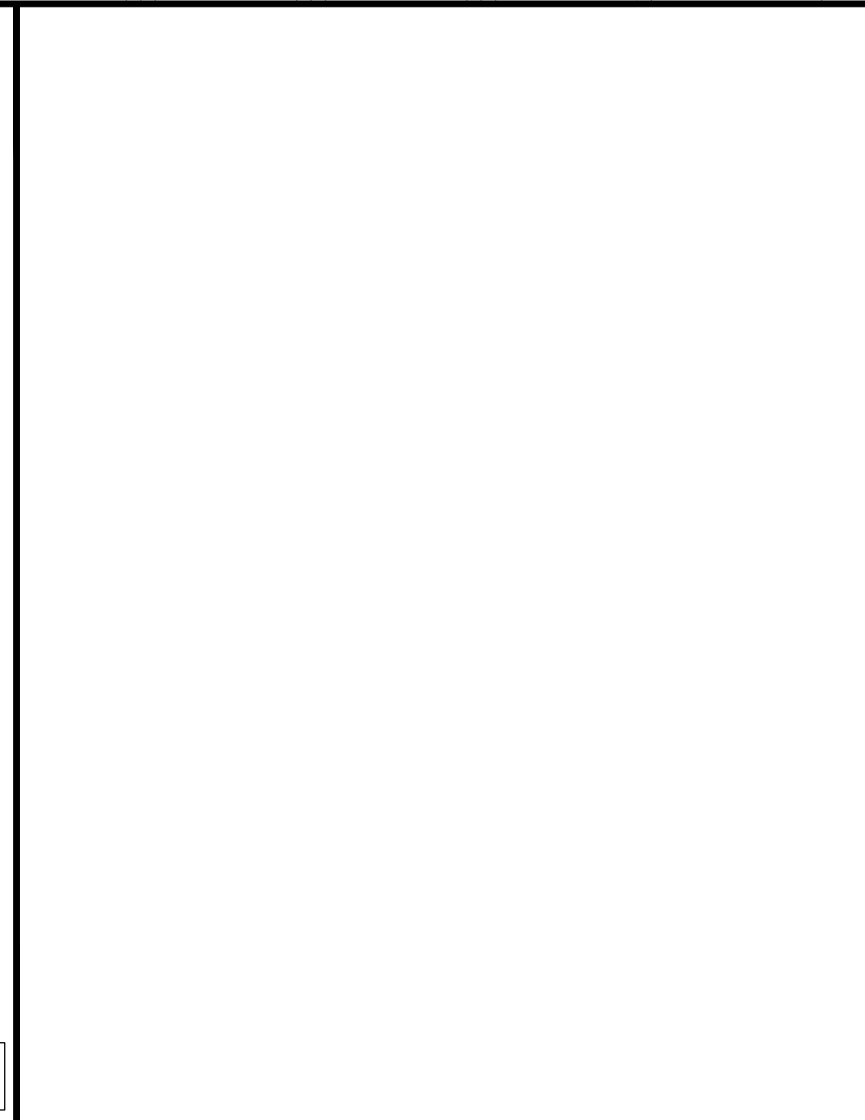

LEGEND  
 EW = EDGE OF WALK  
 BC = BACK OF CURB  
 EP = EDGE OF PAVEMENT

ILLINOIS SWANSEA WATERLOO EDWARDSVILLE PEORIA  
 MISSOURI ST. CHARLES ST. LOUIS  
 TENNESSEE NASHVILLE

**THOUVENOT, WADE & MOERCHEN, INC.**  
 SWANSEA OFFICE  
 4940 OLD COLLINSVILLE ROAD  
 SWANSEA, ILLINOIS 62226  
 (618) 624-4488  
 WWW.TWM-INC.COM

PROF. LICENSE	NUMBER
IL PROF. DESIGN FIRM	184-001220
IL PROF. ENGR. CORP.	62-035370
IL PROF. STR. ENGR. CORP.	81-005202
IL PROF. LAND SURV. CORP.	048-000029
MO. PROF. ENGR. CORP.	001528
MO. LAND SURVEYING CORP.	000346
TN. PROF. ENGR. FIRM	8974

SEAL

SIGNATURE: *Christopher D. Kleister*  
 DATE SIGNED: JUNE 17, 2019  
 LICENSE EXPIRATION: NOV. 30, 2019

IMPROVEMENT PLANS  
 JUNE 17, 2019

REV.	DATE	DESCRIPTION
1	6/7/2019	PER CITY REVIEW
2	6/17/2019	PER CITY REVIEW
3		
4		

DRAWN BY: LEM  
 DESIGNED BY: MJM  
 CHECKED BY: MJM  
 APPROVED BY: MJM  
 PROJECT NO: D01160158B

PROJECT:  
 COUNTRY CLUB HILLS PHASE III  
 CITY OF WATERLOO  
 MONROE COUNTY  
 ILLINOIS

TITLE:  
 ROADWAY JOINT LOCATIONS  
 AND ADA ACCESSIBILITY  
 SPOT GRADING PLAN

P:\160158B\160158B-PLANS-PHASE-3.dwg Plotted By: chuester



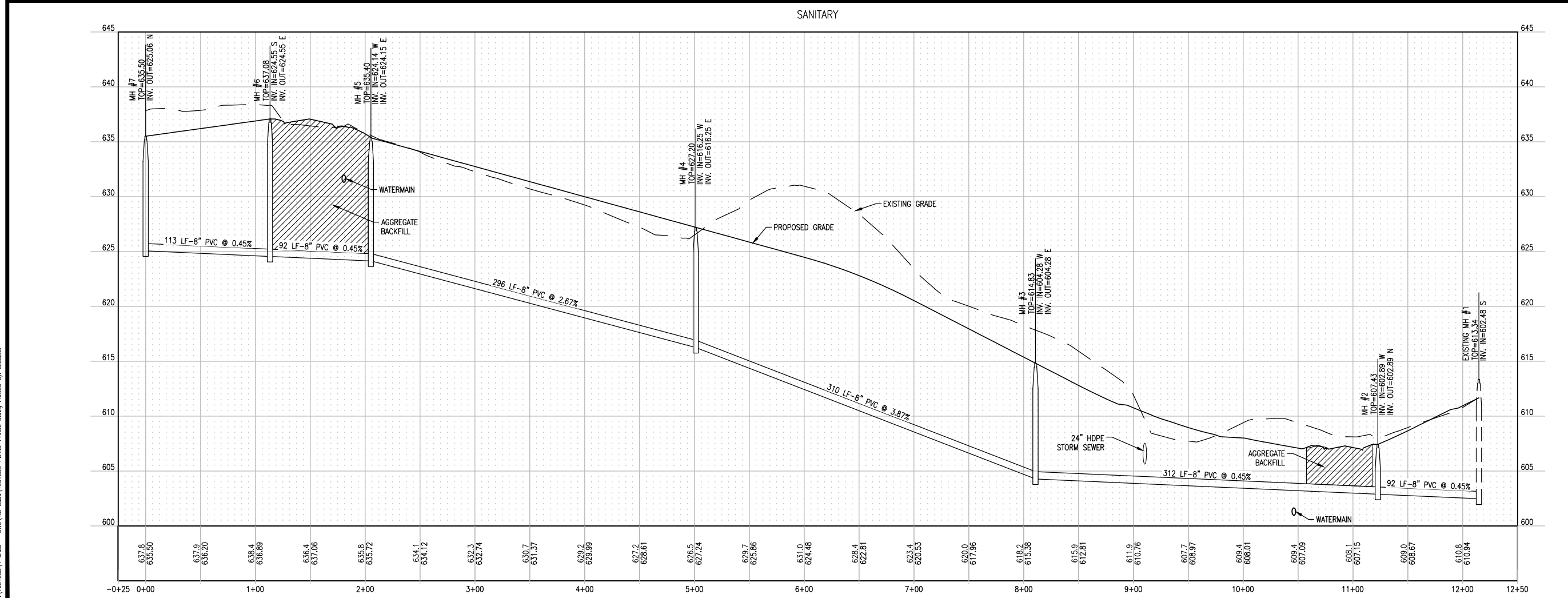
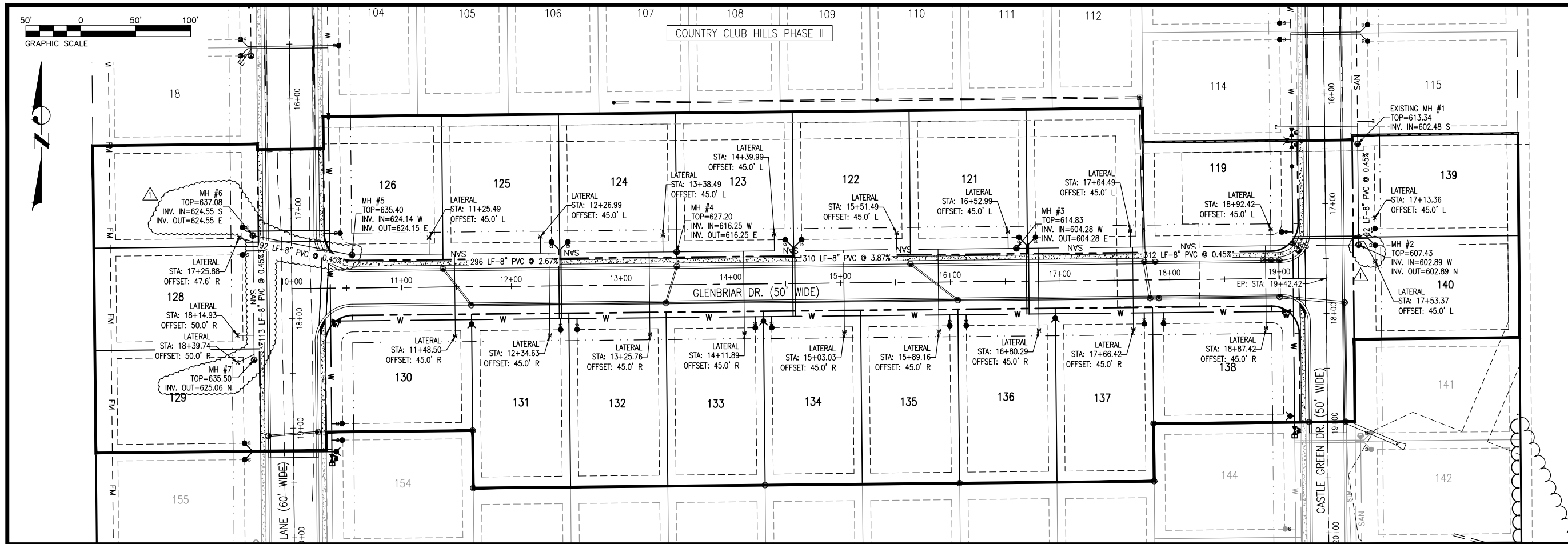

**TWM**  
 CONSULTING ENGINEERING  
 GEOSPATIAL SERVICES

ILLINOIS SWANSEA  
 WATERLOO  
 EDWARDSVILLE  
 PEORIA

MISSOURI ST. CHARLES  
 ST. LOUIS

TENNESSEE | NASHVILLE

**THOUVENOT, WADE  
 & MOERCHEN, INC.**

SWANSEA OFFICE  
 4940 OLD COLLINSVILLE ROAD  
 SWANSEA, ILLINOIS  
 62226  
 (618) 624-4488  
 WWW.TWM-INC.COM

PROF. LICENSE	NUMBER
IL PROF. DESIGN FIRM	184-001220
IL PROF. ENGR. CORP.	62-035370
IL PROF. STR. ENGR. CORP.	81-005202
IL PROF. LAND SURV. CORP.	048-000029
MO. PROF. ENGR. CORP.	001528
MO. LAND SURVEYING CORP.	000346
TN. PROF. ENGR. FIRM	8974

SEAL

SIGNATURE: *Christopher D. Kleiter*  
 DATE SIGNED: JUNE 17, 2019  
 LICENSE EXPIRATION: NOV. 30, 2019

IMPROVEMENT PLANS  
 JUNE 17, 2019

REV.	DATE	DESCRIPTION
1	6/7/2019	PER CITY REVIEW

DRAWN BY: LEM  
 DESIGNED BY:  
 CHECKED BY: MJM  
 APPROVED BY: MJM  
 PROJECT NO: D01160158B

PROJECT:  
 COUNTRY CLUB HILLS PHASE III  
 CITY OF WATERLOO  
 MONROE COUNTY  
 ILLINOIS

TITLE:  
 SANITARY SEWER  
 PLAN AND PROFILE

P:\160158B\160158B-PLANS-PHASE-3.dwg Plotted By: cluester

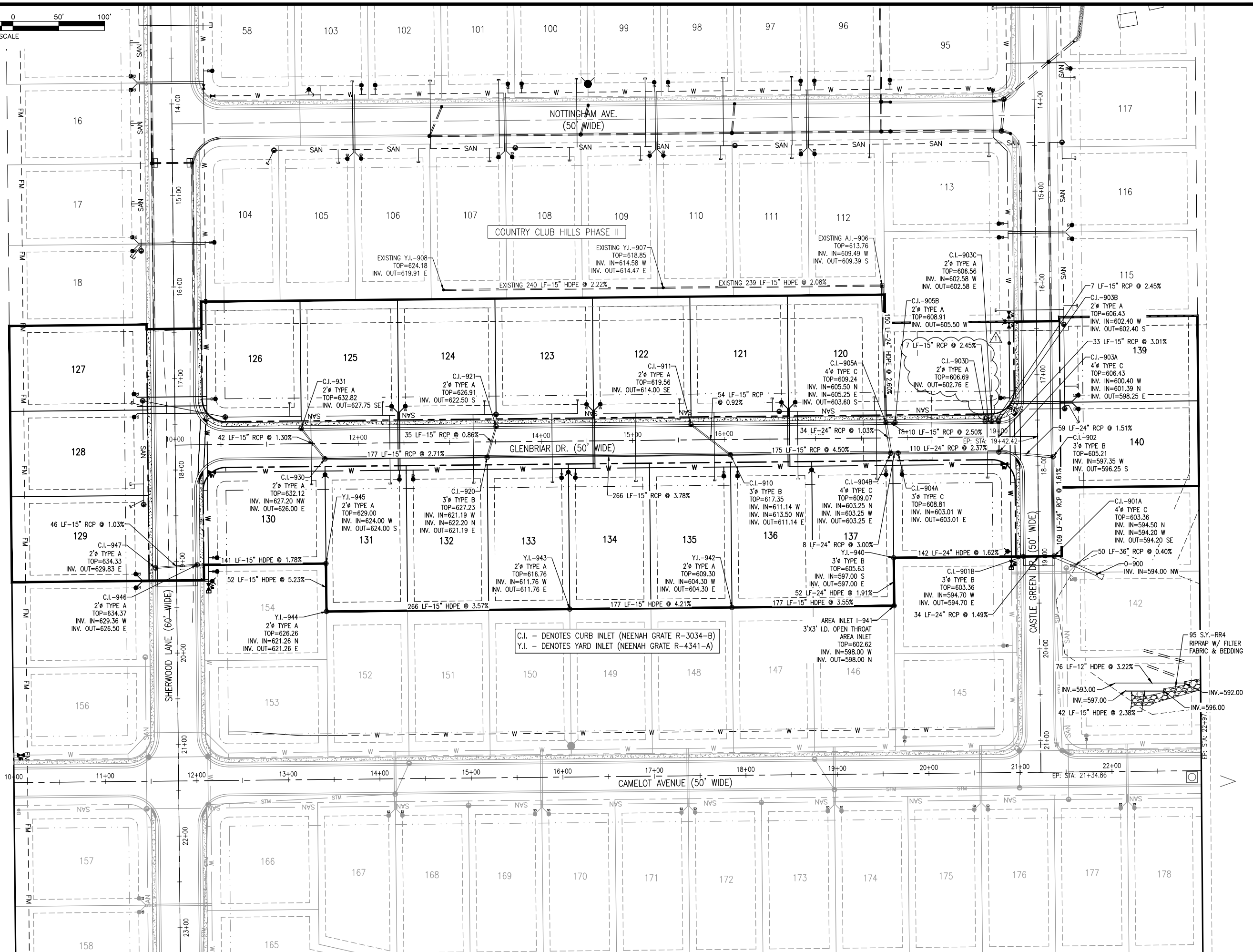
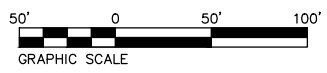

P:\160158B\CADD - DWG\4-5 Sub\160158B-PLANS-PHASE-3.dwg Plotted By: chuester



**CONSULTING ENGINEERING  
GEOSPATIAL SERVICES**

ILLINOIS SWANSEA  
WATERLOO  
EDWARDSVILLE  
PEORIA

MISSOURI ST. CHARLES  
ST. LOUIS

TENNESSEE | NASHVILLE

**THOUVENOT, WADE  
& MOERCHEN, INC.**

SWANSEA OFFICE  
4940 OLD COLLINSVILLE ROAD  
SWANSEA, ILLINOIS  
62226  
(618) 624-4488  
WWW.TWM-INC.COM

PROF. LICENSE	NUMBER
IL PROF. DESIGN FIRM	184-001220
IL PROF. ENGR. CORP.	62-035370
IL PROF. STR. ENGR. CORP.	81-005202
IL PROF. LAND SURV. CORP.	048-000029
MO. PROF. ENGR. CORP.	001528
MO. LAND SURVEYING CORP.	000346
TN. PROF. ENGR. FIRM	8974

SEAL

SIGNATURE:  
DATE SIGNED: JUNE 17, 2019  
LICENSE EXPIRATION: NOV. 30, 2019

IMPROVEMENT PLANS  
JUNE 17, 2019

REV.	DATE	DESCRIPTION
1	6/17/2019	PER CITY REVIEW

DRAWN BY: LEM  
DESIGNED BY: MJM  
CHECKED BY: MJM  
APPROVED BY: MJM  
PROJECT NO: D01160158B

PROJECT:  
COUNTRY CLUB HILLS PHASE III  
CITY OF WATERLOO  
MONROE COUNTY  
ILLINOIS

TITLE:  
STORM SEWER PLAN





I-947 TO I-901A

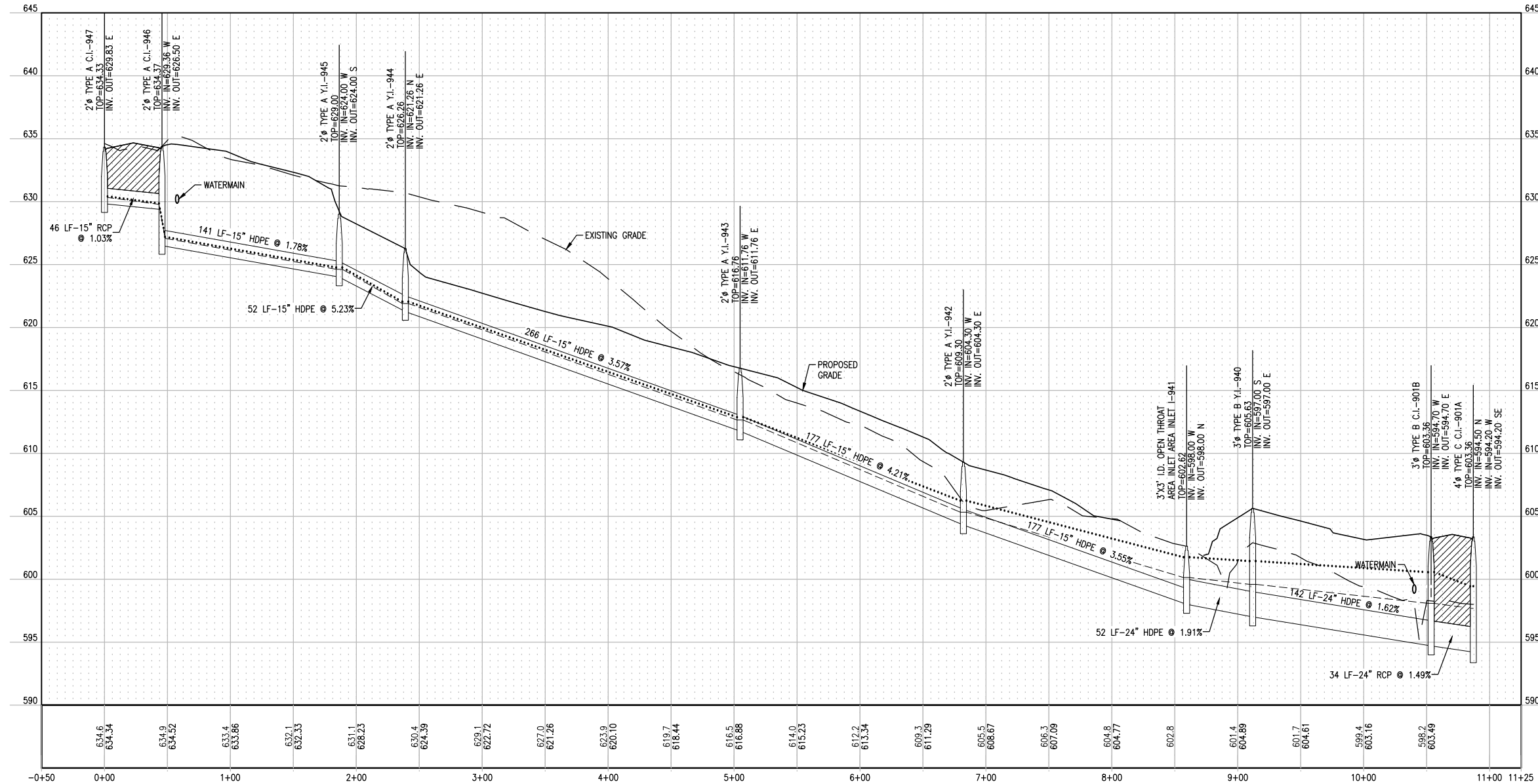

SCALE:  
 HORIZONTAL: 1" = 50'  
 VERTICAL: 1" = 5'

---	=	EXISTING GRADE
—	=	PROPOSED GRADE
—	=	STORM SEWER
---	=	10-YEAR HYDRAULIC GRADELINE
.....	=	100-YEAR HYDRAULIC GRADELINE
▨	=	AGGREGATE BACKFILL



CONSULTING ENGINEERING  
 GEOSPATIAL SERVICES

ILLINOIS | SWANSEA  
 WATERLOO  
 EDWARDSVILLE  
 PEORIA  
 MISSOURI | ST. CHARLES  
 ST. LOUIS  
 TENNESSEE | NASHVILLE

**THOUVENOT, WADE  
 & MOERCHEN, INC.**

SWANSEA OFFICE  
 4940 OLD COLLINSVILLE ROAD  
 SWANSEA, ILLINOIS  
 62226  
 (618) 624-4488  
 WWW.TWM-INC.COM

PROF. LICENSE	NUMBER
IL PROF. DESIGN FIRM	184-001220
IL PROF. ENGR. CORP.	62-035370
IL PROF. STR. ENGR. CORP.	81-005202
IL PROF. LAND SURV. CORP.	048-000029
MO. PROF. ENGR. CORP.	001528
MO. LAND SURVEYING CORP.	000346
TN. PROF. ENGR. FIRM	8974

SEAL

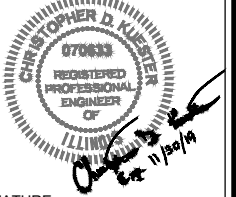

SIGNATURE:  
 DATE SIGNED: JUNE 17, 2019  
 LICENSE EXPIRATION: NOV. 30, 2019

IMPROVEMENT PLANS  
 JUNE 17, 2019

REV.	DATE	DESCRIPTION
△		
△		
△		
△		

DRAWN BY: LEM  
 DESIGNED BY:  
 CHECKED BY: MJM  
 APPROVED BY: MJM  
 PROJECT NO: D01160158B

PROJECT:  
 COUNTRY CLUB HILLS PHASE III  
 CITY OF WATERLOO  
 MONROE COUNTY  
 ILLINOIS

TITLE:  
 STORM SEWER PROFILES

P:\160158B\CADD - DWG\4-5 Subd\160158B-PLANS-PHASE 3.dwg Plotted By: dkuester

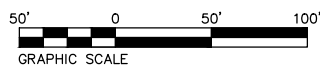

NOTES:

1. ALL AREAS DISTURBED WITHIN THE LIMITS OF IMPROVEMENTS SHALL BE SEEDED WITH MIXTURE CLASS 1, IN ACCORDANCE WITH THE ILLINOIS DEPARTMENT OF TRANSPORTATION STANDARD SPECIFICATIONS FOR ROAD AND BRIDGE CONSTRUCTION BEING:
  - KY BLUEGRASS: 55lbs./ACRE
  - PERENNIAL RYEGRASS: 35lbs./ACRE
  - CREeping RE FESCUE: 25lbs./ACRE
2. MULCHING SHALL BE PROVIDED IN ACCORDANCE WITH MULCH METHOD 2, PROCEDURE 2 PER THE SAME STANDARD SPECIFICATION BEING:
  - PLACING AND STABILIZING STRAW AT 2 TONS/ACRE, ANCHOR STRAW BY USE OF DULL BLADED DISK.
3. ANY AREA TO BE LEFT VOID OF VEGETATION FOR MORE THAN 21 DAYS SHALL HAVE TEMPORARY SEEDING AND MULCH APPLIED. THIS SHOULD BE DONE ANY TIME OF THE YEAR.
4. SILT FENCE SHOULD BE REGULARLY CHECKED AND CLEANED AS NECESSARY.
5. SILT FENCE TO BE INSTALLED ALONG BACK OF CURBS ONCE ROAD CONSTRUCTION COMPLETED.
6. NO UTILITY BOXES SHALL BE INSTALLED IN OVERLAND FLOW PATHS
7. ALL TEMPORARY EROSION CONTROL MATERIALS SHALL BE REMOVED BY CONTRACTOR UPON THE ESTABLISHED GROWTH OF VEGETATION
8. CONSTRUCTION ENTRANCES TO BE INSTALLED IN ACCORDANCE WITH NRCS' ILLINOIS URBAN MANUAL-STABILIZED CONSTRUCTION ENTRANCE"

LEGEND

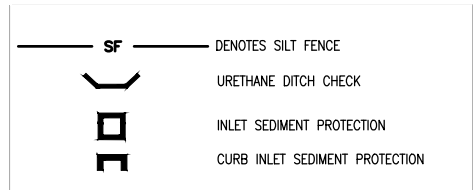

LOT NO.	FIRST FLOOR ELEV.	LOWEST FLOOR ELEV.	LOWEST OPENING	LOT TYPE
119	611.50	601.50	610.00	INGRADE
120	614.50	604.50	611.00	INGRADE
121	619.50	609.50	616.00	INGRADE
122	624.50	604.50	621.00	INGRADE
123	627.50	617.50	623.00	INGRADE
124	630.50	620.50	626.00	INGRADE
125	633.50	623.50	630.00	INGRADE
126	635.00	625.00	634.00	INGRADE
127	639.00	629.00	638.00	INGRADE
128	638.00	637.00	636.00	INGRADE
129	636.50	626.50	635.00	INGRADE
130	636.50	626.50	633.00	INGRADE
131	633.00	623.00	623.00	WALKOUT
132	631.00	621.00	621.00	WALKOUT
133	629.00	619.00	619.00	WALKOUT
134	626.00	616.00	616.00	WALKOUT
135	622.00	612.00	612.00	WALKOUT
136	618.50	608.50	608.50	WALKOUT
137	613.50	603.50	607.00	LOOKOUT
138	608.50	598.50	606.00	INGRADE
139	611.50	601.50	605.00	INGRADE
140	607.50	597.50	602.00	INGRADE

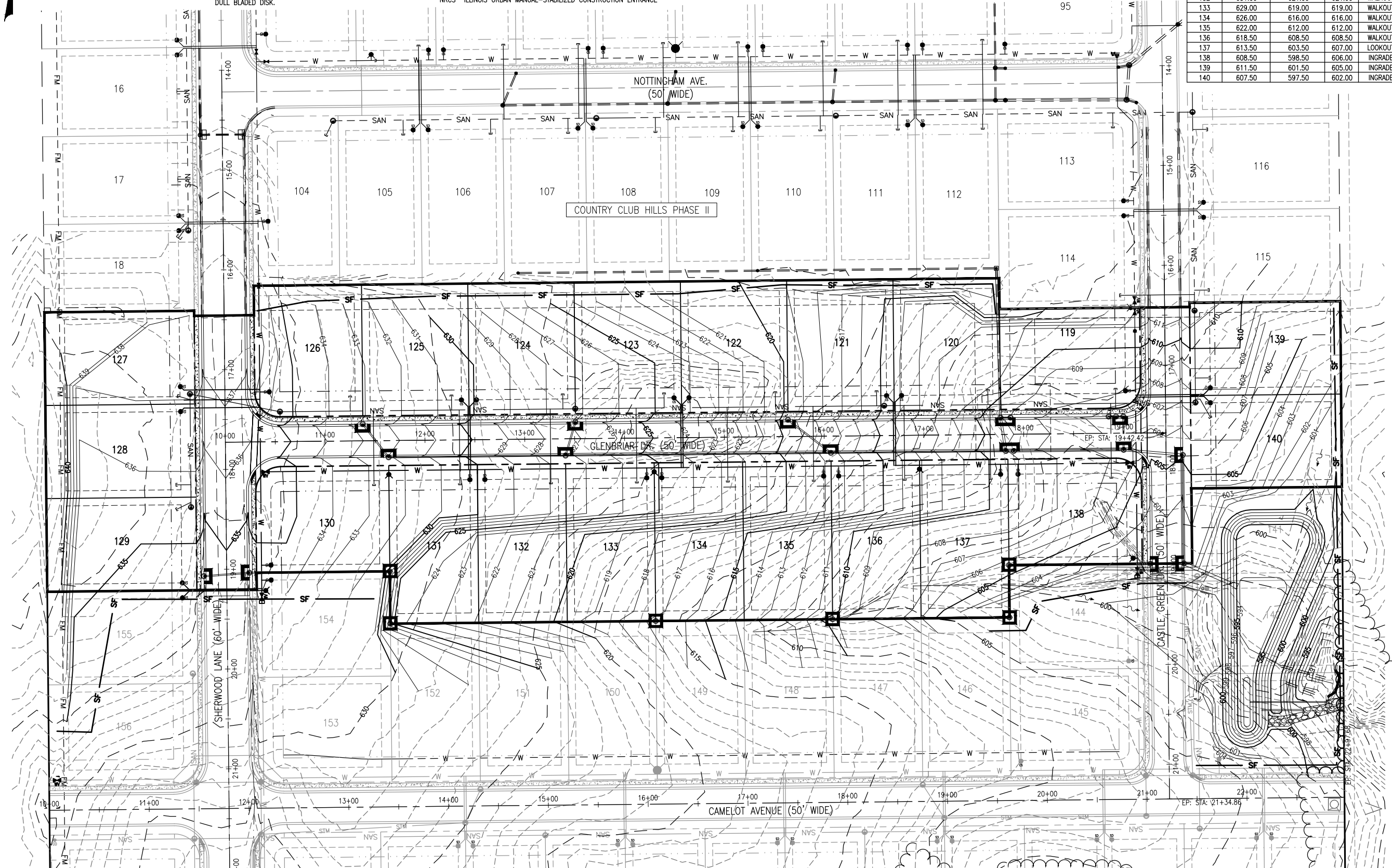

**CONSULTING ENGINEERING  
GEOSPATIAL SERVICES**

ILLINOIS | SWANSEA  
WATERLOO  
EDWARDSVILLE  
PEORIA

MISSOURI | ST. CHARLES  
ST. LOUIS

TENNESSEE | NASHVILLE

**THOUVENOT, WADE  
& MOERCHEN, INC.**

SWANSEA OFFICE  
4940 OLD COLLINSVILLE ROAD  
SWANSEA, ILLINOIS  
62226  
(618) 624-4488  
WWW.TWM-INC.COM

PROF. LICENSE	NUMBER
IL PROF. DESIGN FIRM	184-001220
IL PROF. ENGR. CORP.	62-035370
IL PROF. STR. ENGR. CORP.	81-005202
IL PROF. LAND SURV. CORP.	048-000029
MO. PROF. ENGR. CORP.	001528
MO. LAND SURVEYING CORP.	000346
TN. PROF. ENGR. FIRM	8974

SEAL

SIGNATURE: *Christopher D. Kleister*  
DATE SIGNED: JUNE 17, 2019  
LICENSE EXPIRATION: NOV. 30, 2019

IMPROVEMENT PLANS  
JUNE 17, 2019

REV.	DATE	DESCRIPTION
△		
△		
△		
△		

DRAWN BY: LEM  
DESIGNED BY: LEM  
CHECKED BY: MJM  
APPROVED BY: MJM  
PROJECT NO: D01160158B

PROJECT:  
COUNTRY CLUB HILLS PHASE III  
CITY OF WATERLOO  
MONROE COUNTY  
ILLINOIS

TITLE:  
GRADING AND EROSION  
CONTROL PLAN

P:\01158B\4-CADD - DWG\4-5 Sub\01160158B-PLANS-PHASE 3.dwg Plotted By: chuester



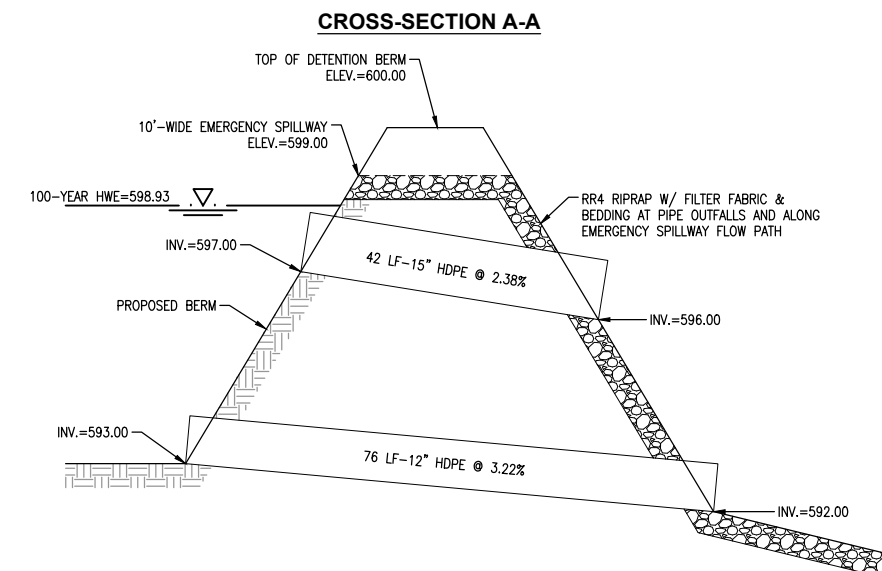
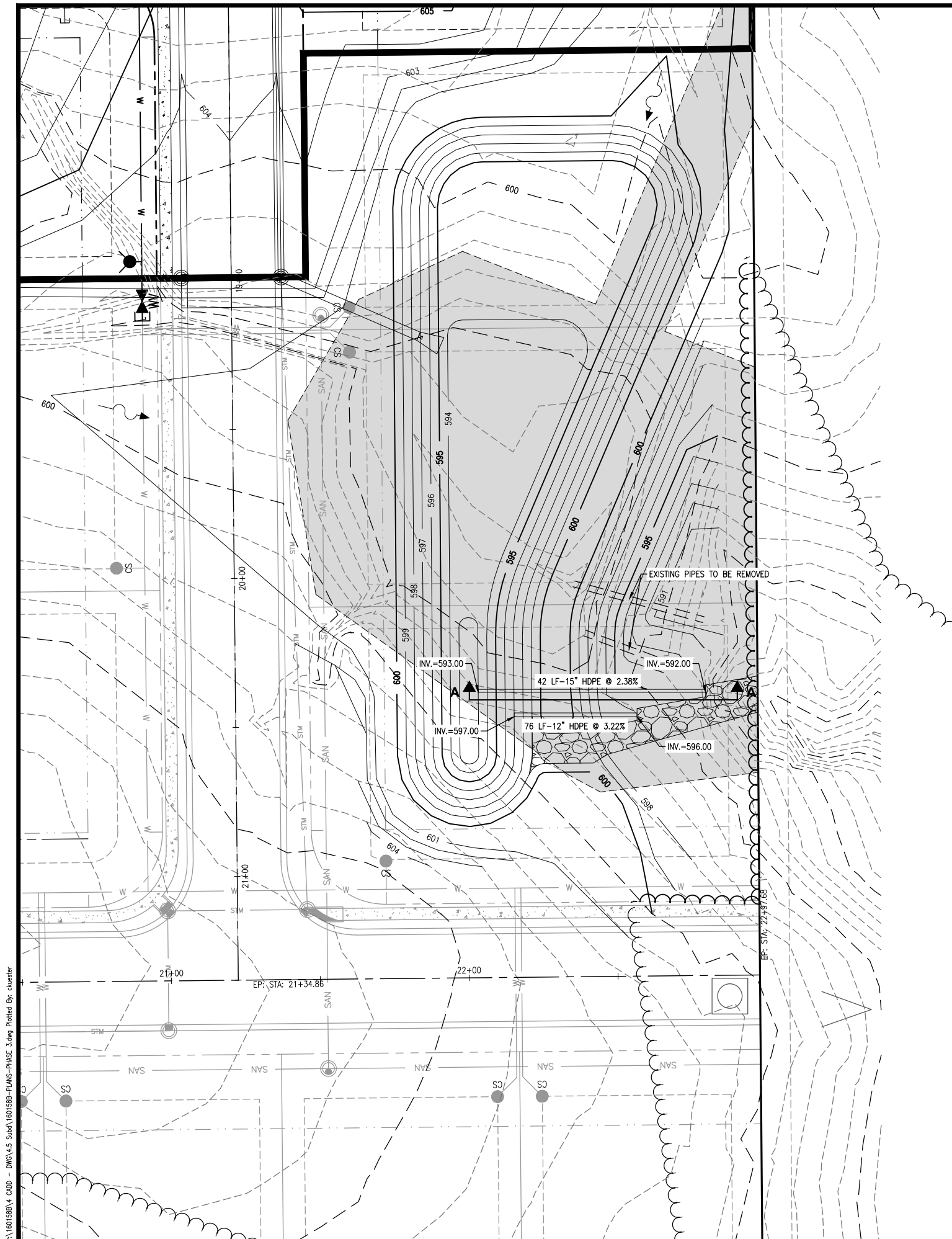

CONSULTING ENGINEERING  
GEOSPATIAL SERVICES

ILLINOIS SWANSEA  
WATERLOO  
EDWARDSVILLE  
PEORIA

MISSOURI ST. CHARLES  
ST. LOUIS

TENNESSEE | NASHVILLE

**THOUVENOT, WADE  
& MOERCHEN, INC.**

SWANSEA OFFICE  
4940 OLD COLLINSVILLE ROAD  
SWANSEA, ILLINOIS  
62226  
(618) 624-4488  
WWW.TWM-INC.COM

PROF. LICENSE	NUMBER
IL. PROF. DESIGN FIRM	184-001220
IL. PROF. ENGR. CORP.	62-035370
IL. PROF. STR. ENGR. CORP.	81-005202
IL. PROF. LAND SURV. CORP.	048-000029
MO. PROF. ENGR. CORP.	001528
MO. LAND SURVEYING CORP.	000346
TN. PROF. ENGR. FIRM	8974

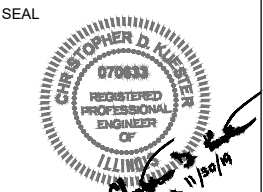

SIGNATURE:  
DATE SIGNED: JUNE 17, 2019  
LICENSE EXPIRATION: NOV. 30, 2019

IMPROVEMENT PLANS  
JUNE 17, 2019

REV.	DATE	DESCRIPTION
△		
△		
△		
△		

DRAWN BY: LEM  
DESIGNED BY:  
CHECKED BY: MJM  
APPROVED BY: MJM  
PROJECT NO: D01160158B

PROJECT:  
  
COUNTRY CLUB HILLS PHASE III  
CITY OF WATERLOO  
MONROE COUNTY  
ILLINOIS

TITLE:  
  
DETENTION OUTLET  
PLAN & PROFILE

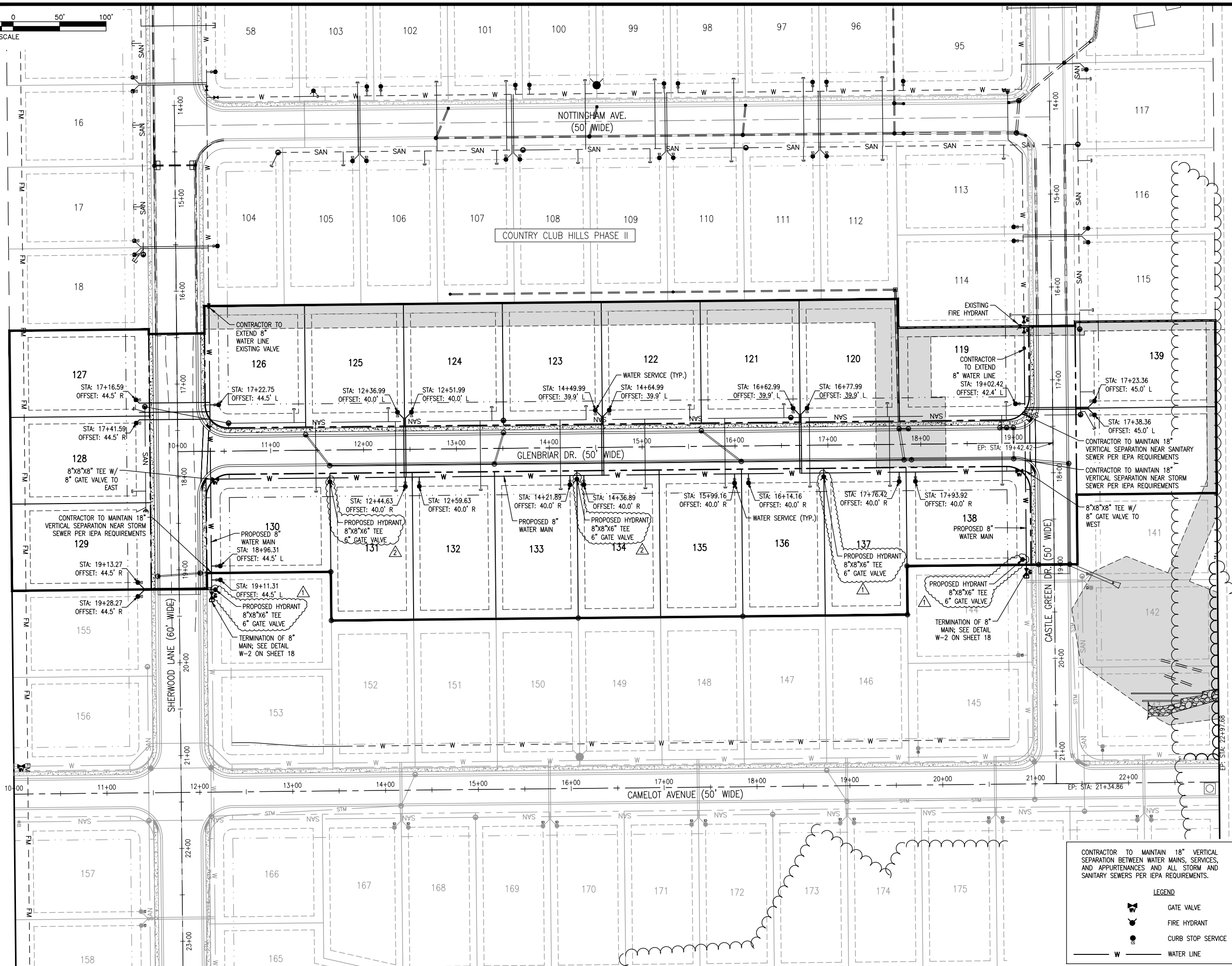
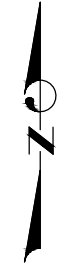

CONTRACTOR TO MAINTAIN 18" VERTICAL SEPARATION BETWEEN WATER MAINS, SERVICES, AND APPURTENANCES AND ALL STORM AND SANITARY SEWERS PER IEPA REQUIREMENTS.

**LEGEND**

- GATE VALVE
- FIRE HYDRANT
- CURB STOP SERVICE
- WATER LINE



CONSULTING ENGINEERING  
GEOSPATIAL SERVICES

ILLINOIS SWANSEA  
WATERLOO  
EDWARDSVILLE  
PEORIA

MISSOURI ST. CHARLES  
ST. LOUIS

TENNESSEE | NASHVILLE

**THOUVENOT, WADE  
& MOERCHEN, INC.**

SWANSEA OFFICE  
4940 OLD COLLINSVILLE ROAD  
SWANSEA, ILLINOIS  
62226  
(618) 624-4488  
WWW.TWM-INC.COM

PROF. LICENSE	NUMBER
IL PROF. DESIGN FIRM	184-001220
IL PROF. ENGR. CORP.	62-035370
IL PROF. STR. ENGR. CORP.	81-005202
IL PROF. LAND SURV. CORP.	048-000029
MO. PROF. ENGR. CORP.	001528
MO. LAND SURVEYING CORP.	000346
TN. PROF. ENGR. FIRM	8974

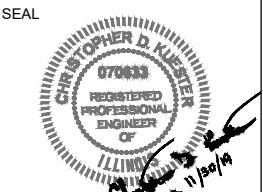

SIGNATURE: *Christopher D. Kleister*  
DATE SIGNED: JUNE 17, 2019  
LICENSE EXPIRATION: NOV. 30, 2019

**IMPROVEMENT PLANS  
JUNE 17, 2019**

REV.	DATE	DESCRIPTION
1	6/7/2019	PER CITY REVIEW
2	6/17/2019	PER CITY REVIEW
3		
4		

DRAWN BY: LEM  
DESIGNED BY: LEM  
CHECKED BY: MJM  
APPROVED BY: MJM  
PROJECT NO: D01160158B

PROJECT:  
COUNTRY CLUB HILLS PHASE III  
CITY OF WATERLOO  
MONROE COUNTY  
ILLINOIS

TITLE:  
WATERMAIN PLAN

P:\160158B\160158B-PLANS-PHASE-3.dwg Plotted By: chuester



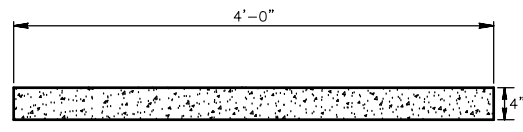

**SIDEWALK DETAIL**

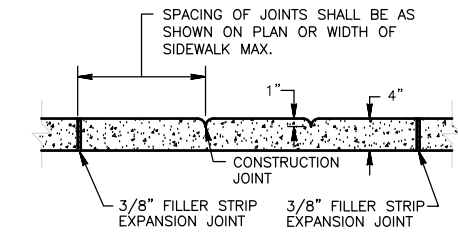

**SIDEWALK JOINT DETAIL**

NOTE: MAXIMUM 25' SPACING BETWEEN EXPANSION JOINTS PROVIDE EXPANSION JOINT MATERIAL AND SEALANT WHERE SIDEWALK AND BUILDING INTERFACE.

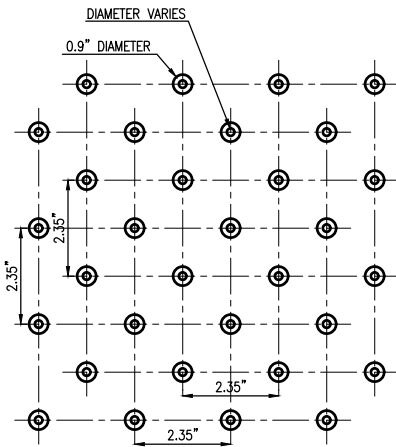

**DETECTABLE WARNING SURFACE**

NOTE: 1. USE SYMONS COLOR HARDNER IN BRICK RED OR APPROVED EQUAL FOR VISUAL CONTRAST ON RAMP

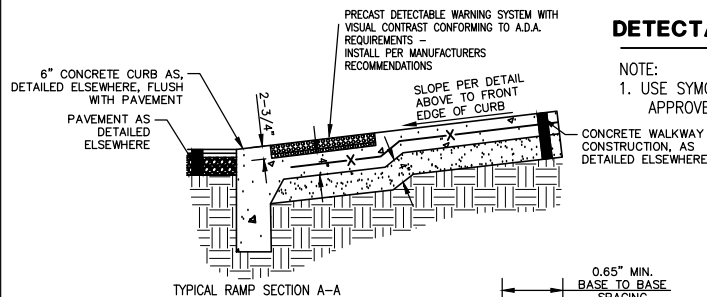

**TYPICAL RAMP SECTION A-A**

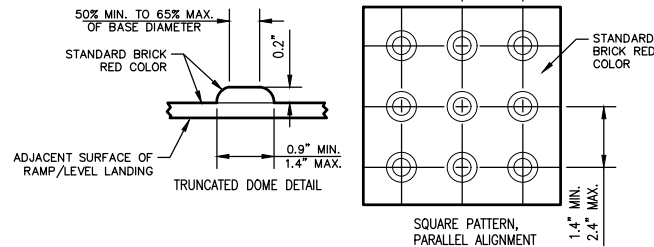

**ADA COMPLIANCE DETAIL**

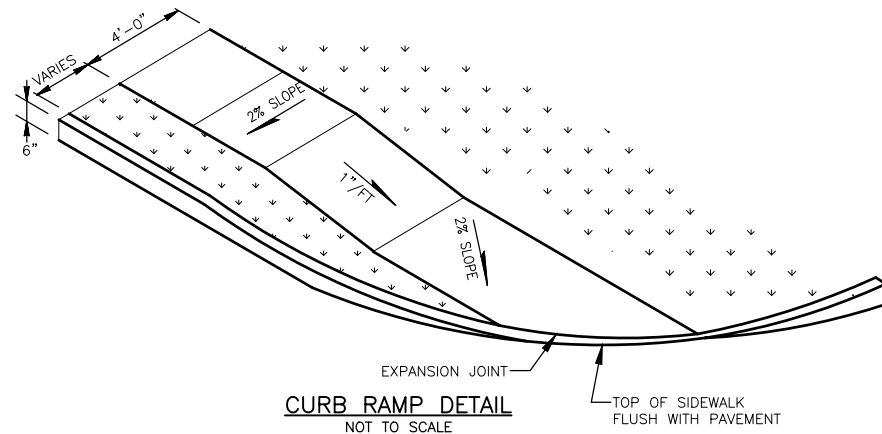

**CURB RAMP DETAIL**  
NOT TO SCALE

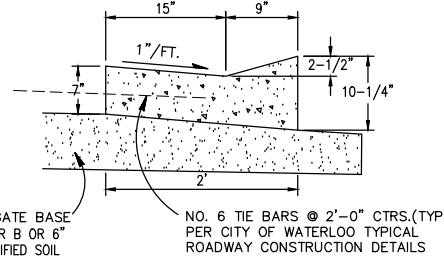

**CITY OF WATERLOO V GUTTER DETAIL**

4" MIN. AGGREGATE BASE COURSE TYPE A OR B OR 6" MINIMUM LIME MODIFIED SOIL OR DEPTH AS REQUIRED BY SOILS INVESTIGATION

NOTE: NO SIDE FLARE REQUIRED IF RAMP IS LOCATED NEXT TO NON-PAVED/LAWN AREA. CURB SHALL BE INSTALLED NEXT TO RAMP.

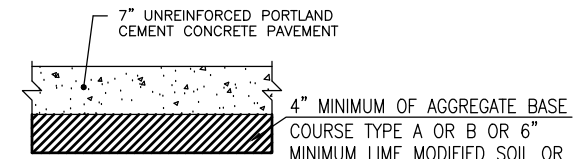

**CONCRETE PAVEMENT**

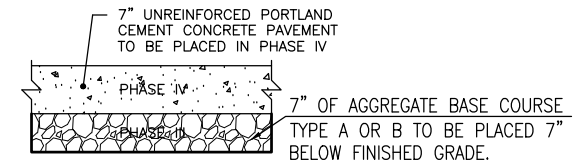

**REMAINDER SHERWOOD LANE SECTION**

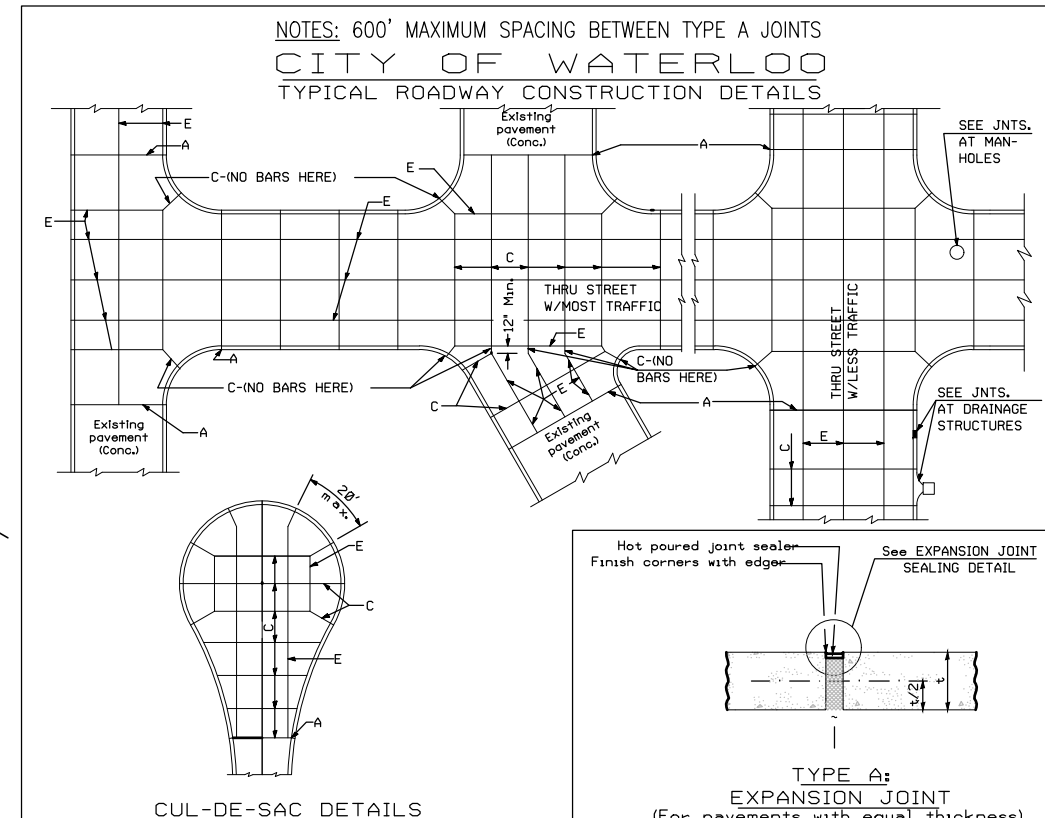

NOTES: 600' MAXIMUM SPACING BETWEEN TYPE A JOINTS  
**CITY OF WATERLOO**  
TYPICAL ROADWAY CONSTRUCTION DETAILS

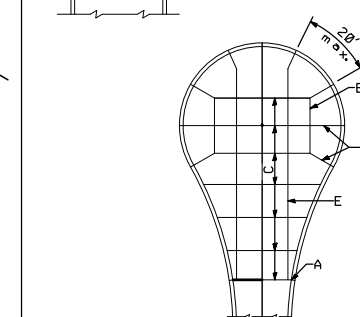

**CUL-DE-SAC DETAILS**

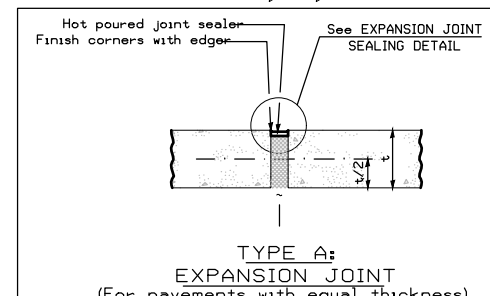

**TYPE A: EXPANSION JOINT**  
(For pavements with equal thickness)

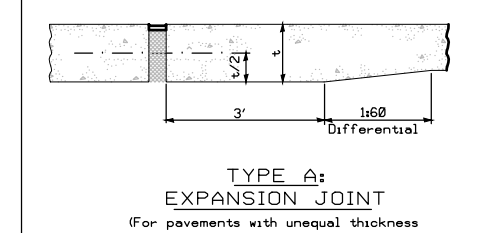

**TYPE A: EXPANSION JOINT**  
(For pavements with unequal thickness See EXPAN. JOINT SEALING DETAIL)

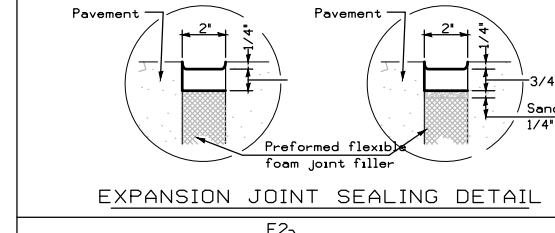

**EXPANSION JOINT SEALING DETAIL**

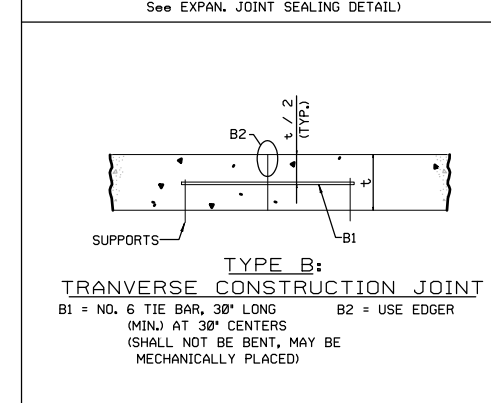

**TYPE B: TRANVERSE CONSTRUCTION JOINT**  
B1 = NO. 6 TIE BAR, 30" LONG (MIN.) AT 30" CENTERS (SHALL NOT BE BENT, MAY BE MECHANICALLY PLACED) B2 = USE EDGER

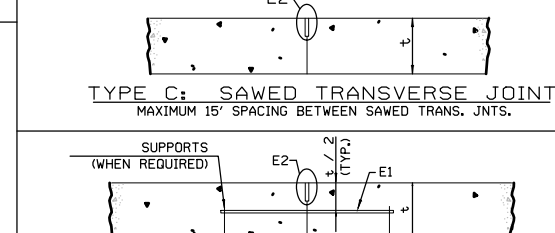

**TYPE C: SAWED TRANSVERSE JOINT**  
MAXIMUM 15' SPACING BETWEEN SAWED TRANS. JNTS.

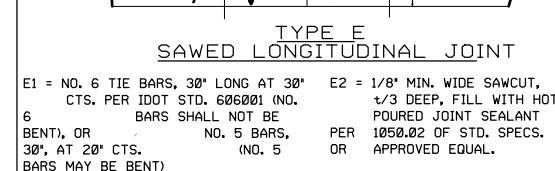

**TYPE E: SAWED LONGITUDINAL JOINT**

E1 = NO. 6 TIE BARS, 30" LONG AT 30" CTS. PER IDOT STD. 606001 (NO. 6 BARS SHALL NOT BE BENT), OR NO. 5 BARS, (NO. 5 BARS MAY BE BENT) E2 = 1/8" MIN. WIDE SAWCUT, +/- 3 DEEP, FILL WITH HOT POURED JOINT SEALANT 1050.02 OF STD. SPECS. OR APPROVED EQUAL.

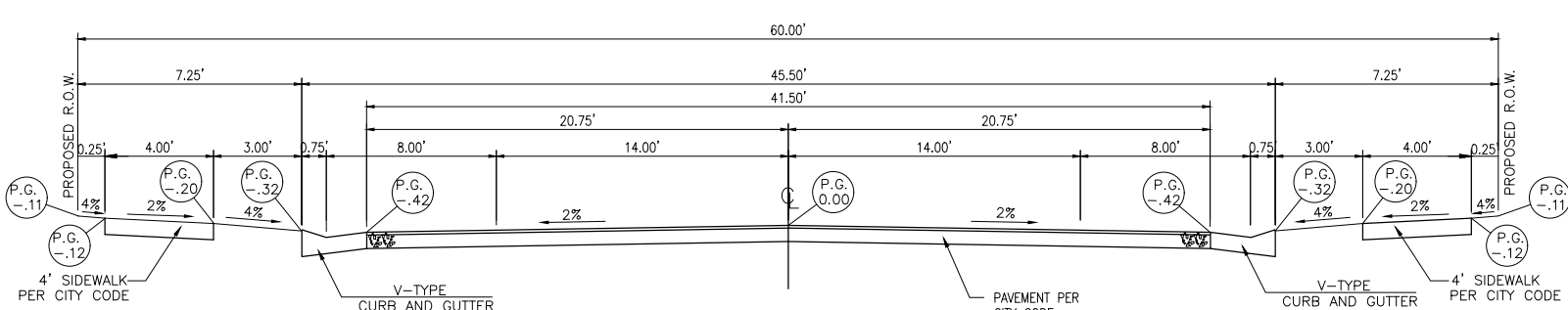

**TYPICAL SECTION 60' ROW**

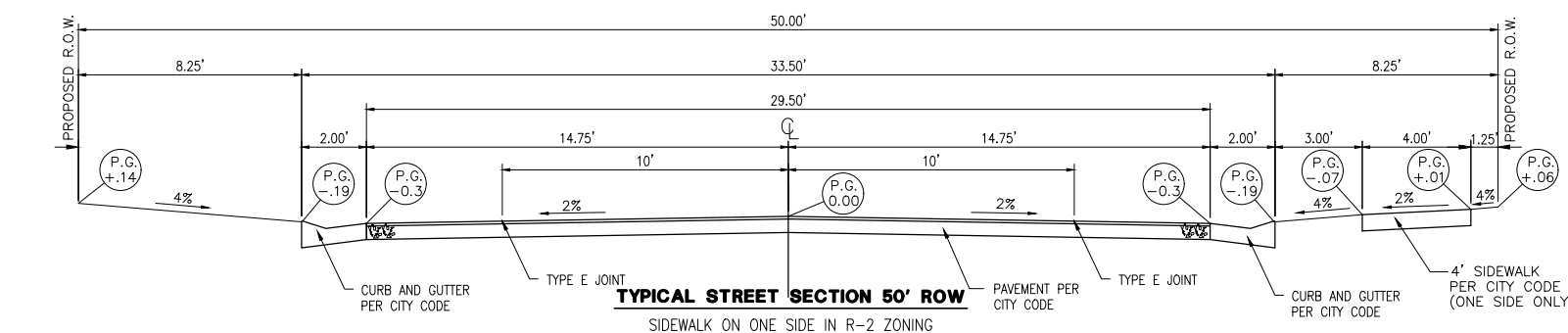

**TYPICAL STREET SECTION 50' ROW**  
SIDEWALK ON ONE SIDE IN R-2 ZONING

**TWM**  
CONSULTING ENGINEERING  
GEOSPATIAL SERVICES

ILLINOIS SWANSEA WATERLOO EDWARDSVILLE PEORIA  
MISSOURI ST. CHARLES ST. LOUIS  
TENNESSEE NASHVILLE

**THOUVENOT, WADE & MOERCHEN, INC.**

SWANSEA OFFICE  
4940 OLD COLLINSVILLE ROAD  
SWANSEA, ILLINOIS  
62226  
(618) 624-4488  
WWW.TWM-INC.COM

PROF. LICENSE NUMBER  
IL PROF. DESIGN FIRM 184-001220  
IL PROF. ENGR. CORP. 62-035370  
IL PROF. STR. ENGR. CORP. 81-005202  
IL PROF. LAND SURV. CORP. 048-000029  
MO. PROF. ENGR. CORP. 001528  
MO. LAND SURVEYING CORP. 000346  
TN. PROF. ENGR. FIRM 8974

SEAL

SIGNATURE:  
DATE SIGNED: JUNE 17, 2019  
LICENSE EXPIRATION: NOV. 30, 2019

IMPROVEMENT PLANS  
JUNE 17, 2019

REV.	DATE	DESCRIPTION
△		
△		
△		
△		

DRAWN BY: LEM  
DESIGNED BY: LEM  
CHECKED BY: MJM  
APPROVED BY: MJM  
PROJECT NO: D01160158B

PROJECT:  
COUNTRY CLUB HILLS PHASE III  
CITY OF WATERLOO  
MONROE COUNTY  
ILLINOIS

TITLE:  
PAVEMENT DETAILS



CITY OF WATERLOO  
TYPICAL SANITARY SEWER AND SANITARY SEWER FORCEMAIN CONSTRUCTION DETAILS

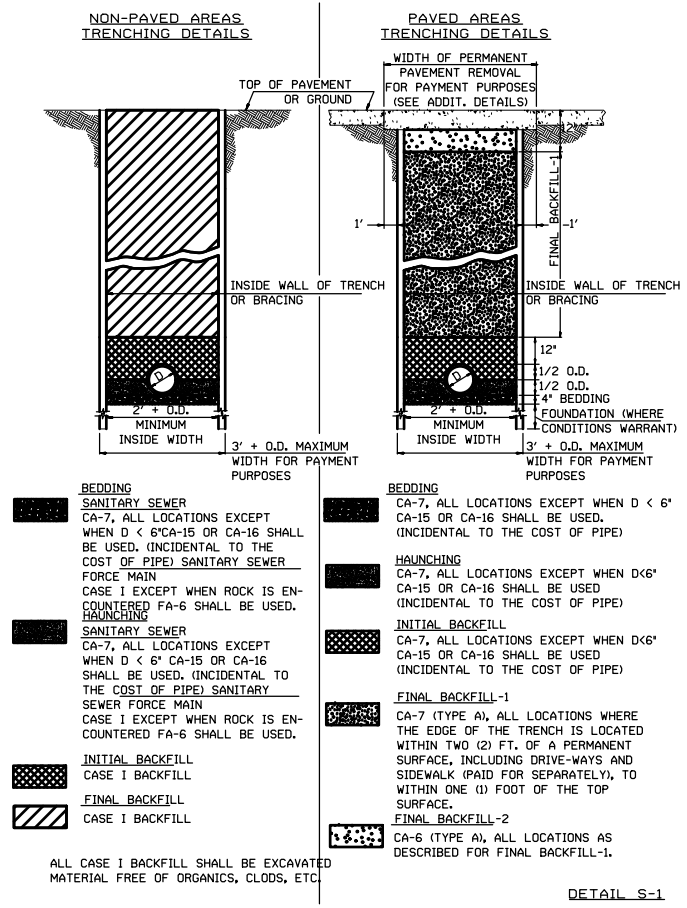

DETAIL S-1

CITY OF WATERLOO  
TYPICAL SANITARY SEWER CONSTRUCTION DETAILS

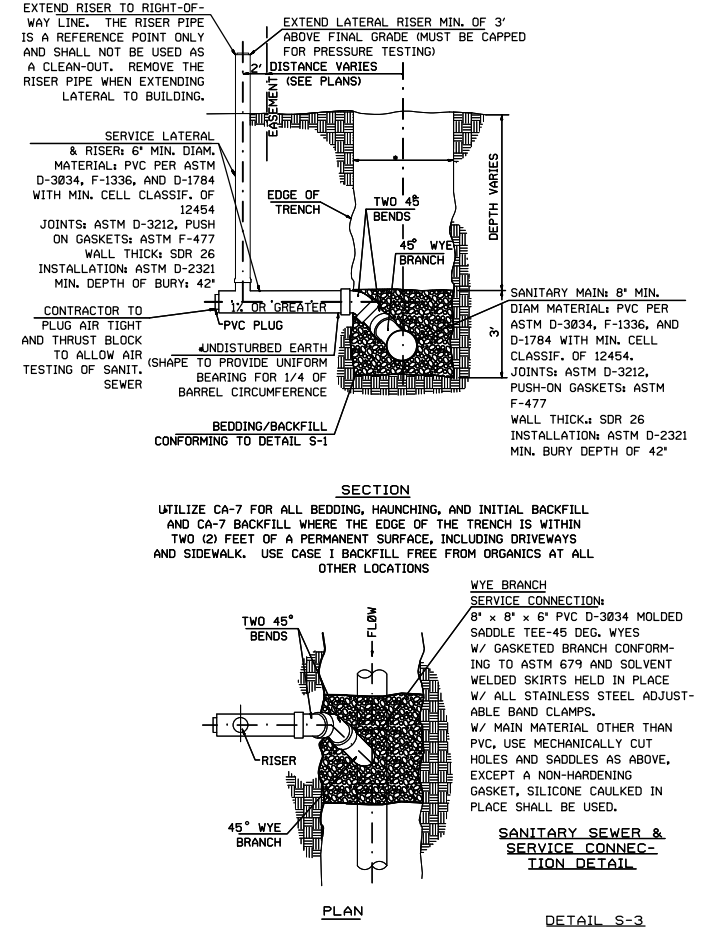

DETAIL S-3

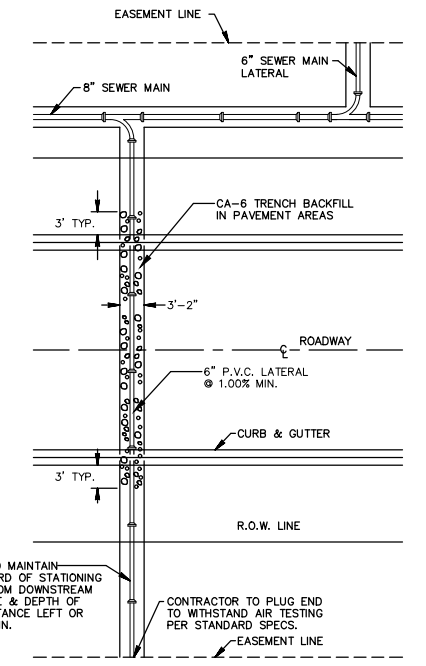

SEWER LATERAL DETAIL

SPECIFICATIONS: ALL WORK, INSTALLATION, MATERIALS, PROCEDURES, AND TESTING SHALL CONFORM TO THE LATEST EDITION OF THE ILLINOIS STANDARD SPECIFICATIONS FOR WATER AND SEWER MAIN CONSTRUCTION.

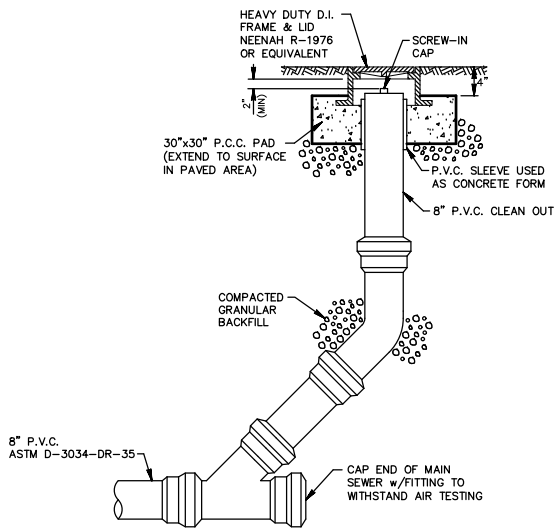

CLEANOUT DETAIL

SPECIFICATIONS: SANITARY SEWER PIPE SHALL CONFORM TO ASTM D-3034-DR-35 WITH ELASTOMERIC JOINTS IN CONFORMANCE WITH ASTM D-3212.

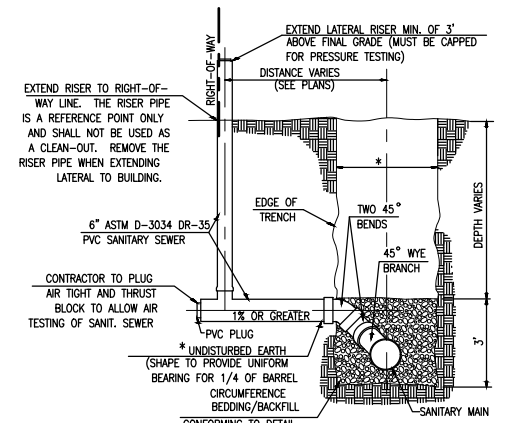

* UTILIZE FA-6 FOR ALL BEDDING, HAUNCHING, AND INITIAL BACKFILL AND CA-6 BACKFILL WHERE THE EDGE OF THE TRENCH IS WITHIN TWO (2) FEET OF A PERMANENT SURFACE, INCLUDING DRIVEWAYS AND SIDEWALK. USE CASE 1 BACKFILL FREE FROM ORGANICS AT ALL OTHER LOCATIONS

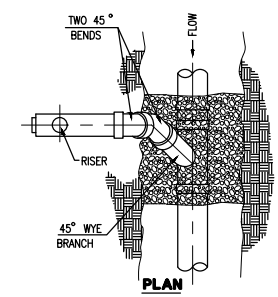

TYPICAL SANITARY SEWER CONSTRUCTION DETAILS

CITY OF WATERLOO  
TYPICAL SANITARY SEWER CONSTRUCTION DETAILS

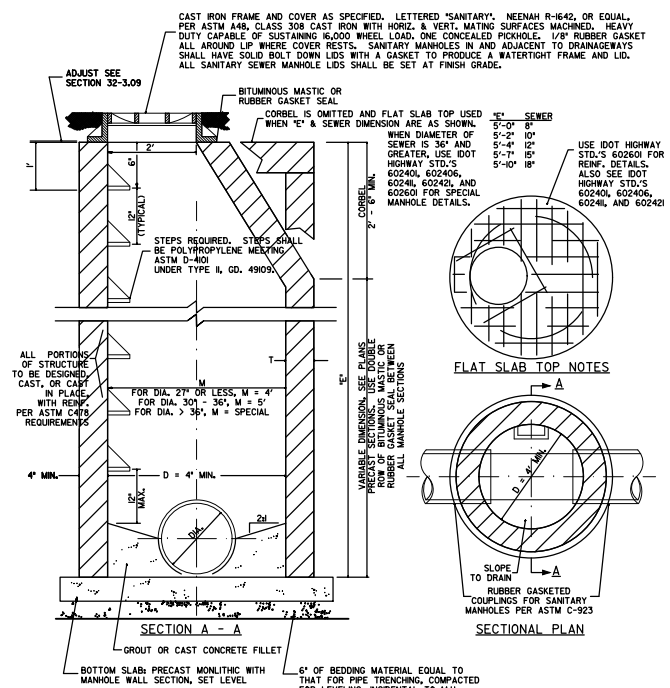

SANITARY SEWER MANHOLE DETAILS

DETAIL S-2

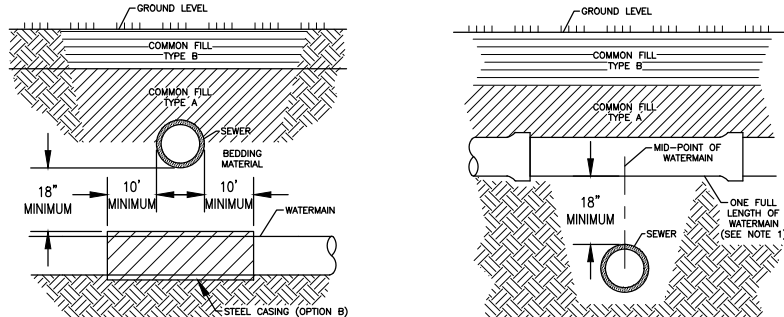

OPTION A - PRESSURE CLASS SEWER MAIN  
1.) REPLACE EXISTING SEWER WITH A PRESSURE CLASS MAIN IN LIEU OF CASING THE WATER MAIN.  
2.) THE SEWER SHALL BE REPLACED A MINIMUM OF 10' EACH SIDE OF THE WATERMAIN.

OPTION B - WATER INSTALLATION  
1.) MID-POINT OF THE FULL LENGTH OF THE WATER MAIN IS TO BE CENTERED ABOVE SEWER LINE.  
2.) PROVIDE ADEQUATE SUPPORT FOR THE WATER MAIN TO PREVENT DAMAGE DUE TO SETTLEMENT.

NOTES:  
1.) FOLLOW TRENCH MATERIAL DETAIL WHEN BACK-FILLING WATER MAIN.  
2.) THE SELECTED OPTION MUST BE APPROVED BY AN IL-AMC REPRESENTATIVE.  
WATER MAIN CROSSING UNDER SEWER

NOTES:  
1.) FOLLOW TRENCH MATERIAL DETAIL WHEN BACK-FILLING WATER MAIN.  
2.) THE SELECTED OPTION MUST BE APPROVED BY AN IL-AMC REPRESENTATIVE.  
WATER MAIN CROSSING OVER SEWER

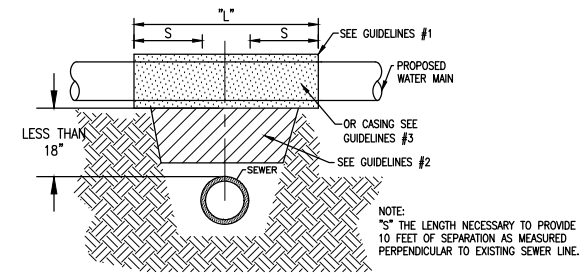

GUIDELINES:  
1. OMIT SELECT GRANULAR EMBEDMENT AND GRANULAR BACKFILL TO ONE (1) FOOT OVER TOP OF WATER MAIN AND USE SELECT EXCAVATED MATERIAL (CLASS IV) AND COMPACT THE LENGTH OF "L".  
2. IF SELECT GRANULAR BACKFILL EXISTS, REMOVE WITHIN WIDTH OF EXISTING SEWER LINE TRENCH AND REPLACE WITH SELECT EXCAVATED MATERIAL (CLASS IV) AND COMPACT.  
3. USE "L" FEET OF WATER MAIN MATERIAL FOR CASING OF PROPOSED WATER MAIN AND SEAL ENDS OF CASING.  
4. POINT LOADS SHALL NOT BE ALLOWED BETWEEN WATER MAIN CASING AND SEWER.

**TWM**  
CONSULTING ENGINEERING  
GEOSPATIAL SERVICES  
ILLINOIS | SWANSEA  
WATERLOO  
EDWARDSVILLE  
PEORIA  
MISSOURI | ST. CHARLES  
ST. LOUIS  
TENNESSEE | NASHVILLE

**THOUVENOT, WADE & MOERCHEN, INC.**  
SWANSEA OFFICE  
4940 OLD COLLINSVILLE ROAD  
SWANSEA, ILLINOIS  
62226  
(618) 624-4488  
WWW.TWM-INC.COM

PROF. LICENSE NUMBER  
IL PROF. DESIGN FIRM 184-001220  
IL PROF. ENGR. CORP. 62-035702  
IL PROF. STR. ENGR. CORP. 81-005202  
IL PROF. LAND SURV. CORP. 048-000029  
MO. PROF. ENGR. CORP. 001528  
MO. LAND SURVEYING CORP. 000346  
TN. PROF. ENGR. FIRM 8974

SEAL  
CHRISTOPHER D. KUESTER  
REGISTERED PROFESSIONAL ENGINEER  
ILLINOIS  
11/29/14

SIGNATURE:  
DATE SIGNED: JUNE 17, 2019  
LICENSE EXPIRATION: NOV. 30, 2019

IMPROVEMENT PLANS  
JUNE 17, 2019

REV.	DATE	DESCRIPTION
△		
△		
△		
△		

DRAWN BY: LEM  
DESIGNED BY: MJM  
APPROVED BY: MJM  
PROJECT NO: D01160158B

PROJECT:  
COUNTRY CLUB HILLS PHASE III  
CITY OF WATERLOO  
MONROE COUNTY  
ILLINOIS

TITLE:  
SANITARY SEWER DETAILS

**NOTE:**  
ALL CONSTRUCTION SHALL BE IN ACCORDANCE WITH THE CITY OF WATERLOO CONSTRUCTION DETAIL BOOK DATED: 6-23-16

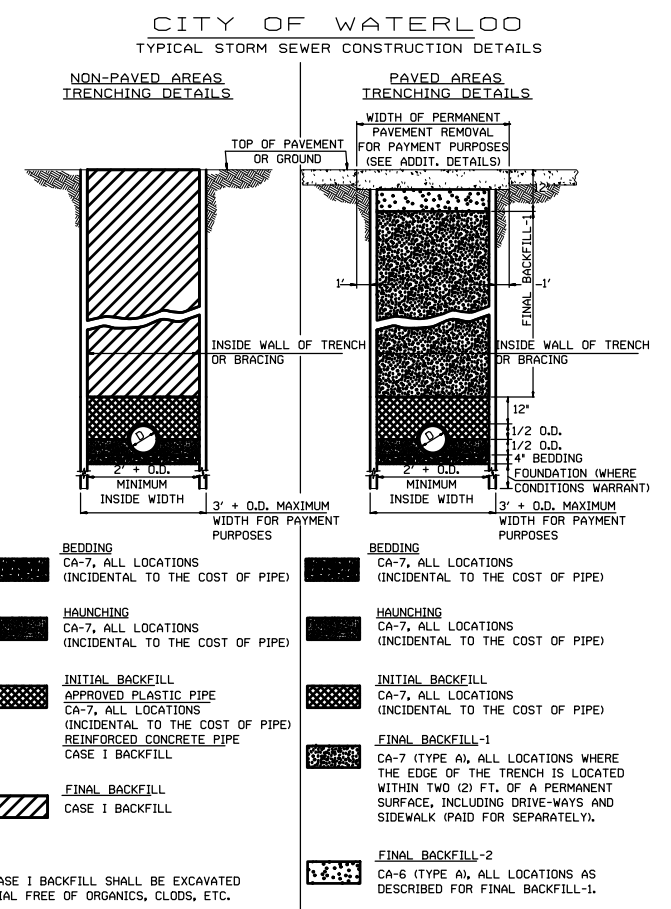
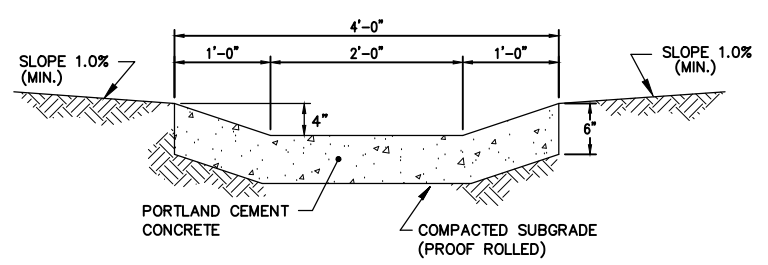
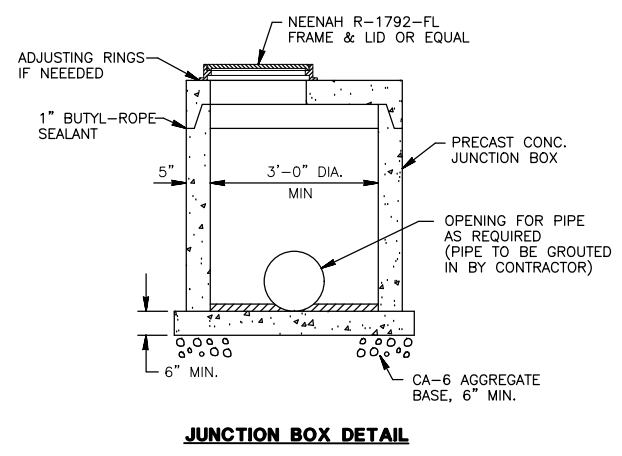
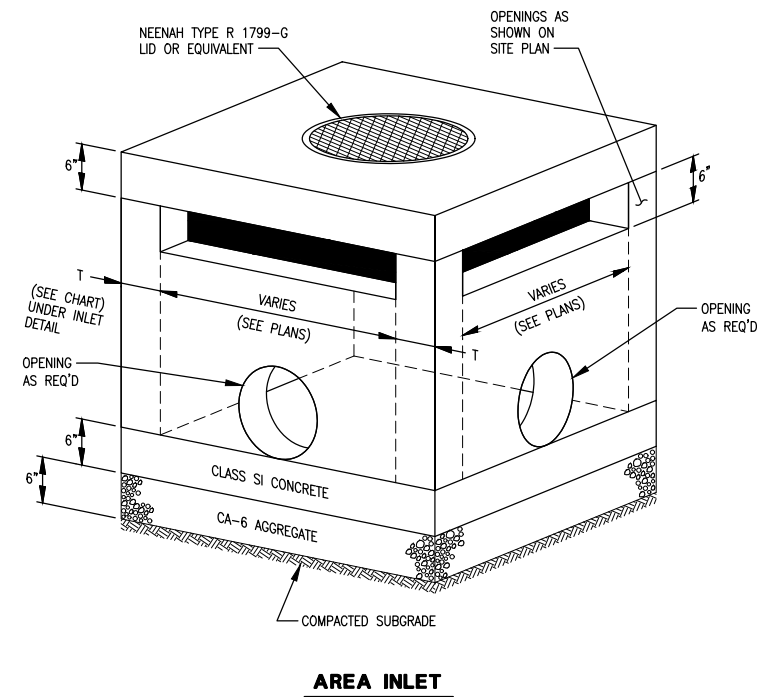
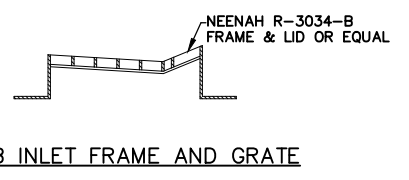
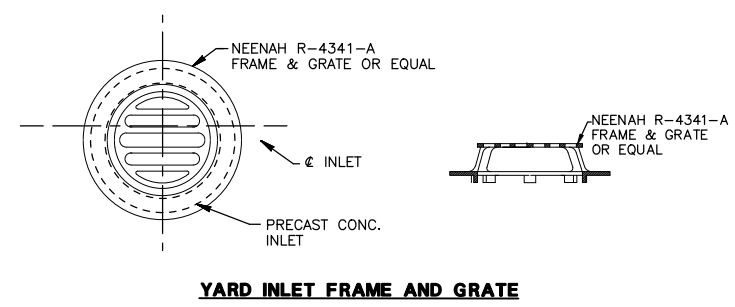
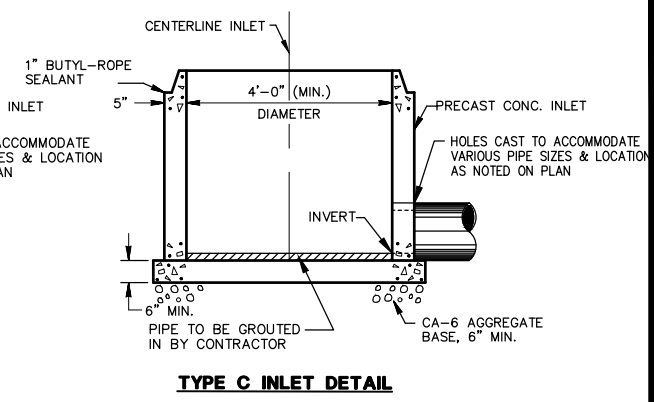
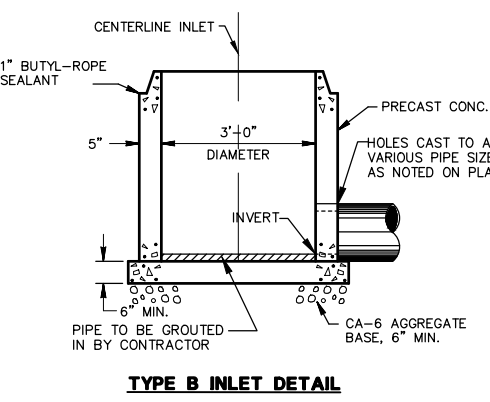
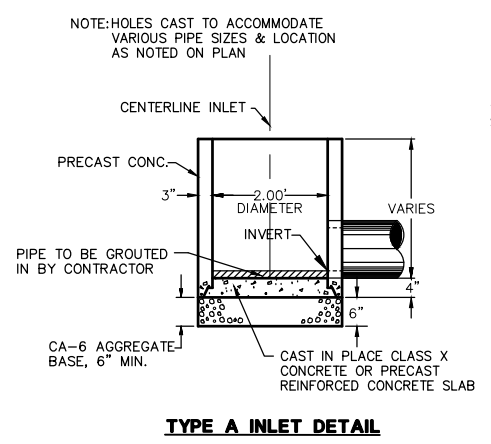
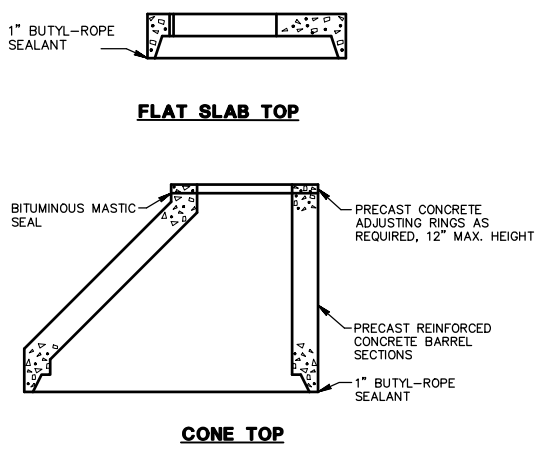
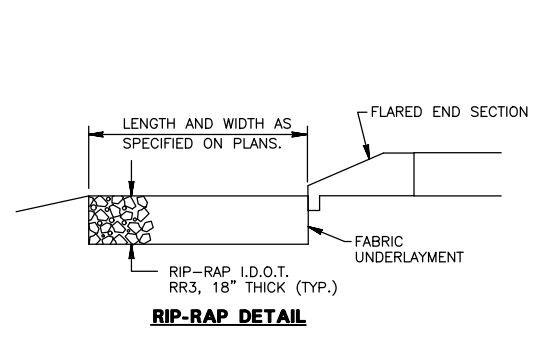

CONSULTING ENGINEERING  
GEOSPATIAL SERVICES

ILLINOIS | SWANSEA  
WATERLOO  
EDWARDSVILLE  
PEORIA  
MISSOURI | ST. CHARLES  
ST. LOUIS  
TENNESSEE | NASHVILLE

**THOUVENOT, WADE  
& MOERCHEN, INC.**

SWANSEA OFFICE  
4940 OLD COLLINSVILLE ROAD  
SWANSEA, ILLINOIS  
62226  
(618) 624-4488  
WWW.TWM-INC.COM

PROF. LICENSE	NUMBER
IL PROF. DESIGN FIRM	184-001220
IL PROF. ENGR. CORP.	62-035370
IL PROF. STR. ENGR. CORP.	81-005202
IL PROF. LAND SURV. CORP.	048-000029
MO. PROF. ENGR. CORP.	001528
MO. LAND SURVEYING CORP.	000346
TN. PROF. ENGR. FIRM	8974

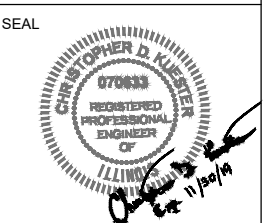

SIGNATURE:  
DATE SIGNED: JUNE 17, 2019  
LICENSE EXPIRATION: NOV. 30, 2019

IMPROVEMENT PLANS  
JUNE 17, 2019

REV.	DATE	DESCRIPTION
△		
△		
△		
△		

DRAWN BY: LEM  
DESIGNED BY: MJM  
CHECKED BY: MJM  
APPROVED BY: MJM  
PROJECT NO: D01160158B

PROJECT:  
COUNTRY CLUB HILLS PHASE III  
CITY OF WATERLOO  
MONROE COUNTY  
ILLINOIS

TITLE:  
STORM SEWER DETAILS

P:\160158B\4_CADD - DWG\4-5_Sub\160158B-PLANS-PHASE 3.dwg Plotted By: chuester



CITY OF WATERLOO  
TYPICAL WATER MAIN CONSTRUCTION DETAILS

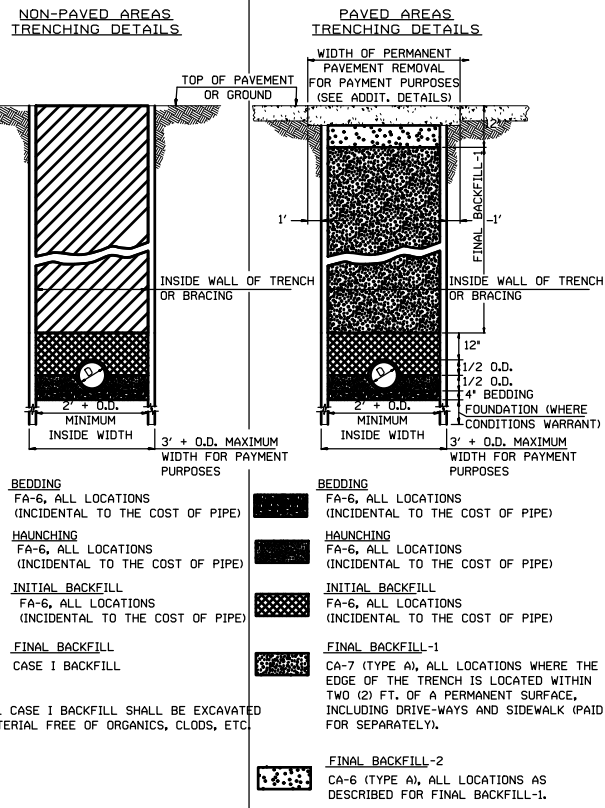

DETAIL W-1

CITY OF WATERLOO  
TYPICAL WATER MAIN CONSTRUCTION DETAILS

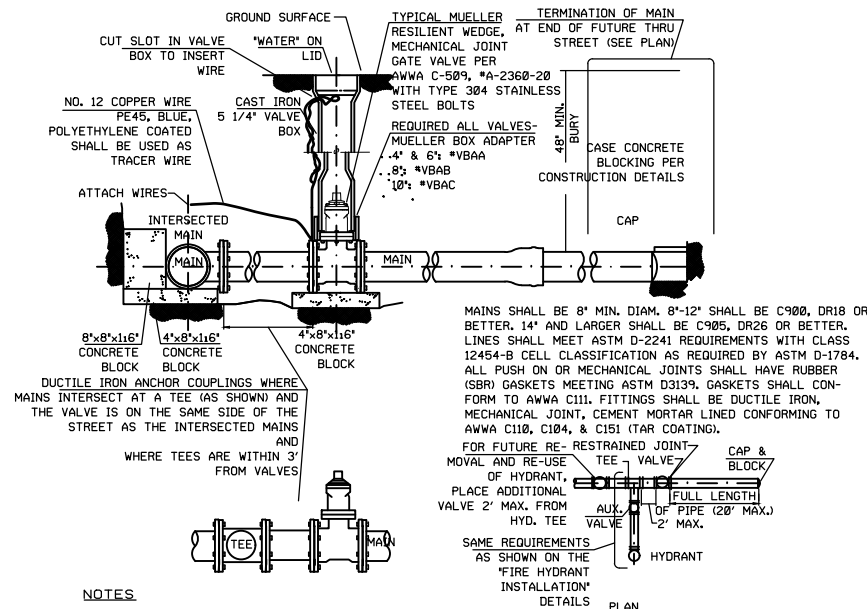

DETAIL W-2

CITY OF WATERLOO  
TYPICAL WATER MAIN CONSTRUCTION DETAILS

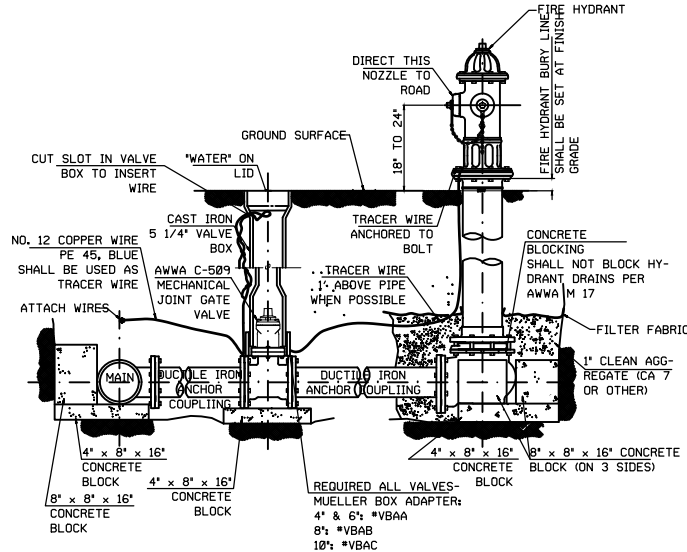

FIRE HYDRANT  
INSTALLATION  
DETAIL W-3

CITY OF WATERLOO  
TYPICAL WATER MAIN CONSTRUCTION DETAILS

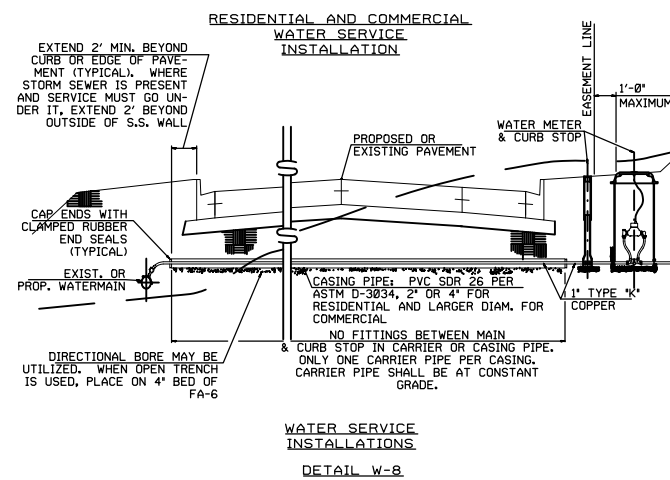

CITY OF WATERLOO  
TYPICAL WATER MAIN CONSTRUCTION DETAILS

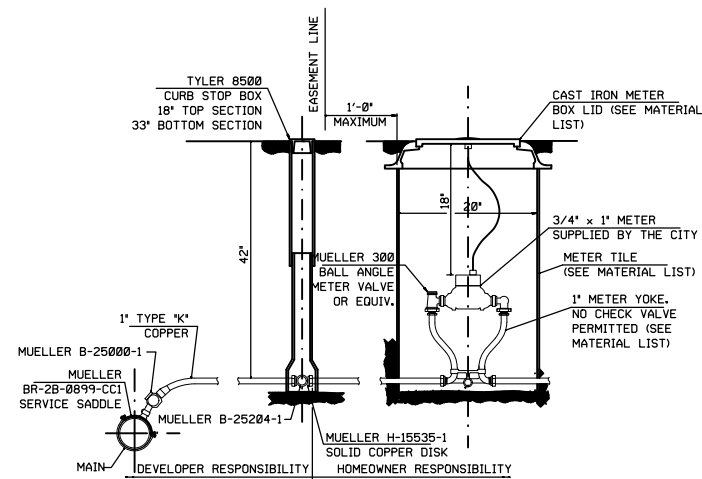

RESIDENTIAL  
WATER SERVICE  
INSTALLATION  
TYPICAL PRESSURES  
DETAIL W-6

WATER MAINS  
WATER MAINS SHALL BE CONSTRUCTED USING (8) INCH (AS SHOWN) PVC-AWWA C900, DR18 PIPE MATERIAL WITH ELASTOMERIC JOINTS IN CONFORMANCE WITH ASTM 3139.

FITTINGS  
FITTINGS SHALL BE DUCTILE IRON, MECHANICAL JOINT AND CEMENT MORTAR LINED. FITTINGS SHALL BE IN ACCORDANCE WITH ANSI/AWWA C110/A21. CEMENT MORTAR LINING SHALL BE IN CONFORMANCE WITH ANSI/AWWA C104/A21.4. THE FITTINGS SHALL BE TAR-COATED IN CONFORMANCE WITH AWWA C151.

RUBBER GASKET JOINTS  
JOINTS FOR PLASTIC PRESSURE PIPE USING FLEXIBLE ELASTOMERIC SEALS SHALL CONFORM WITH ASTM D3139. RUBBER GASKET JOINTS FOR DUCTILE IRON FITTINGS SHALL BE IN CONFORMANCE WITH ANSI/AWWA C111/A21.11.

GATE VALVES-MUELLER  
GATE VALVES SHALL BE RESILIENT WEDGE, MECHANICAL JOINT PER AWWA C-509, #A-2360-20 WITH TYPE 304 STAINLESS STEEL BOLTS, OR EQUIVALENT AS APPROVED BY THE CITY OF WATERLOO.  
GATE VALVES SHALL BE RATED FOR 200 PSI WATER PRESSURE IN THE 2 THROUGH 12 INCH SIZES AND 150 PSI WATER PRESSURE IN THE 14 INCH AND LARGER SIZES. GATE VALVES SHALL HAVE A STUFFING BOX WITH TEFLON PACKING AND THE OPERATING NUT SHALL BE A 2 INCH SQUARE AWWA NUT.

VALVE BOXES-MUELLER  
CAST IRON VALVE BOX ADAPTORS SHALL BE INSTALLED OVER ALL VALVES TO FURNISH OPERATING ACCESS. THE MUELLER BOX ADAPTOR SHALL BE:  
4" & 6" - #VBAA  
8" - #VBAB  
10" - #VCAC  
OR EQUIVALENT AS APPROVED BY THE CITY OF WATERLOO. THE LIDS SHALL HAVE THE WORD "WATER" CAST IN THE LID.

COPPER SERVICE PIPE  
COPPER PIPE SHALL BE COPPER WATER TUBE, TYPE K, SOFT TEMPER, FOR UNDERGROUND SERVICE, CONFORMING TO ASTM B-88 AND B-251. THE PIPE SHALL BE MARKED WITH THE MANUFACTURER'S NAME OR TRADEMARK AND A MARK INDICATIVE OF THE TYPE OF PIPE. THE OUTSIDE DIAMETER OF THE PIPE SHALL CONFORM TO ASTM B251 TABLE 2.

TRACER WIRE  
TRACER WIRE SHALL BE #12 SOLID COPPER PE45 AND BLUE TRACER WIRE (POLYETHYLENE COATED) AND SHALL BE CONNECTED TO ALL VALVES AND HYDRANTS.  
DIRECT BURY SPLICE (3M) SHALL BE USED. TURN OFF POWER BEFORE INSTALLING OR REMOVING CONNECTOR. ALL ELECTRICAL WORK SHOULD BE DONE ACCORDING TO APPROPRIATE ELECTRICAL CODES. 30 V MAXIMUM VOLTAGE.

WIRES SHALL BE STRIPPED 5/8" AND WIRE SHALL BE TWISTED TOGETHER. THE SCOTCHLOK ELECTRICAL SPRING CONNECTOR SHALL BE APPLIED AND TWISTED IN A CLOCKWISE DIRECTION. THE SPLICE SHALL THEN BE INSERTED INTO THE GEL-FILLED INSULATOR TUBE. THE WIRES SHALL BE POSITIONED INTO CHANNELS AND SNAP INSULATOR TUBE COVER CLOSED.

FIRE HYDRANTS  
ALL FIRE HYDRANTS FOR THIS PROJECT SHALL BE MUELLER SUPER CENTURION 250 MODEL A-423 FIRE HYDRANTS WITH APPURTENANT SIX (6) INCH RESILIENT SEAT GATE VALVES IN ACCORDANCE WITH THE CITY OF WATERLOO REQUIREMENTS.

TESTING  
IN CONFORMANCE WITH THE CITY OF WATERLOO REQUIREMENTS.

DISINFECTION  
ALL SECTIONS OF PIPE TO BE DISINFECTED SHALL BE FLUSHED TO REMOVE ANY SOLIDS OR CONTAMINATED MATERIALS. ALL NEW MAINS OR EXTENSIONS TO EXISTING MAINS SHALL BE CHLORINATED SO THAT INITIAL CHLORINE RESIDUAL IS NOT LESS THAN 50 PPM AND THAT A CHLORINE RESIDUAL OF NOT LESS THAN 25 PPM REMAINS AFTER STANDING 24 HOURS IN THE PIPE. FOLLOWING CHLORINATION, ALL TREATED WATER MUST BE FLUSHED AND PIPES FILLED WITH REPLACEMENT WATER WITH CHLORINE RESIDUAL LESS THAN 1 PPM. PROVISIONS MUST BE MADE FOR THE COLLECTION OF WATER SAMPLES TO BE COLLECTED FOR BACTERIOLOGICAL ANALYSIS ON TWO CONSECUTIVE DAYS TAKEN AT 24 HOUR INTERVALS.



CONSULTING ENGINEERING  
GEOSPATIAL SERVICES

ILLINOIS | SWANSEA  
WATERLOO  
EDWARDSVILLE  
PEORIA

MISSOURI | ST. CHARLES  
ST. LOUIS

TENNESSEE | NASHVILLE

THOUVENOT, WADE  
& MOERCHEN, INC.

SWANSEA OFFICE  
4940 OLD COLLINSVILLE ROAD  
SWANSEA, ILLINOIS  
62226  
(618) 624-4488  
WWW.TWM-INC.COM

PROF. LICENSE NUMBER  
IL PROF. DESIGN FIRM 184-001220  
IL PROF. ENGR. CORP. 62-035370  
IL PROF. STR. ENGR. CORP. 81-005202  
IL PROF. LAND SURV. CORP. 048-000029  
MO. PROF. ENGR. CORP. 001528  
MO. LAND SURVEYING CORP. 000346  
TN. PROF. ENGR. FIRM 8974



SIGNATURE:  
DATE SIGNED: JUNE 17, 2019  
LICENSE EXPIRATION: NOV. 30, 2019

IMPROVEMENT PLANS  
JUNE 17, 2019

REV.	DATE	DESCRIPTION
△		
△		
△		
△		

DRAWN BY: LEM  
DESIGNED BY: LEM  
CHECKED BY: MJM  
APPROVED BY: MJM  
PROJECT NO: D01160158B

PROJECT:  
COUNTRY CLUB HILLS PHASE III  
CITY OF WATERLOO  
MONROE COUNTY  
ILLINOIS

TITLE:  
WATERMAIN DETAILS

NOTE:  
ALL CONSTRUCTION SHALL BE IN ACCORDANCE WITH THE CITY OF WATERLOO CONSTRUCTION DETAIL BOOK DATED: 6-23-16

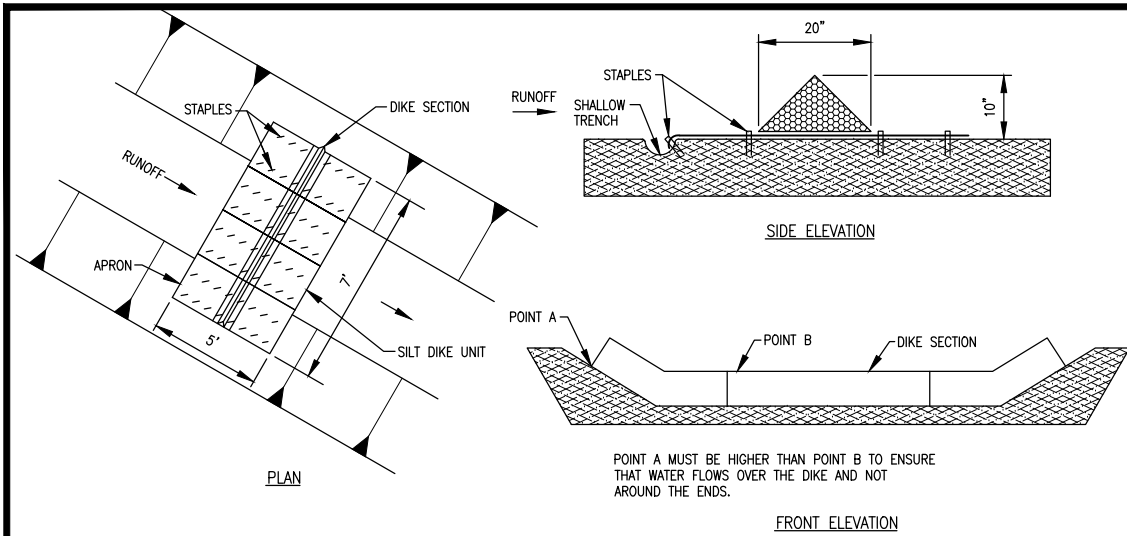

**URETHANE FOAM/GEOTEXTILE DITCH CHECK**

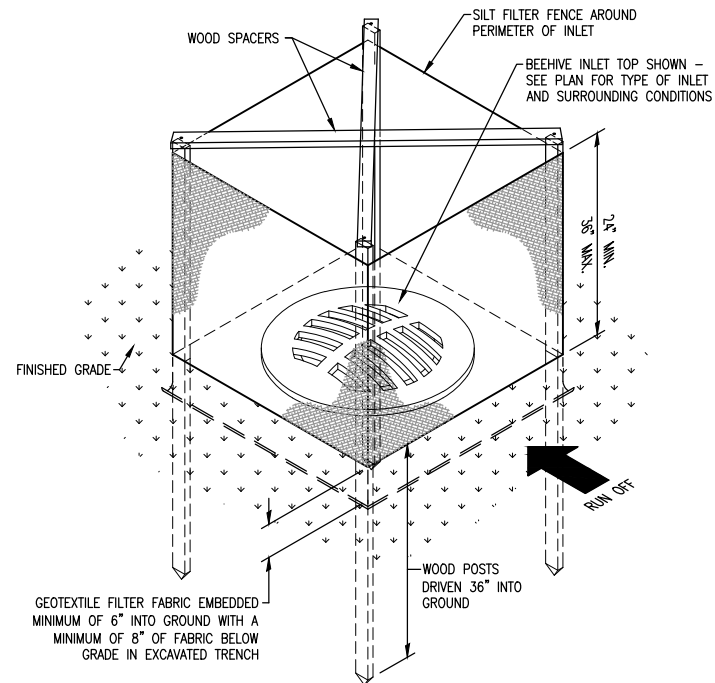

NOTES:  
 EROSION CONTROL LOG CONTAINMENT MESH SHALL BE 100% BIODEGRADABLE, PHOTODEGRADABLE OR RECYCLABLE; AND FILL MATERIAL SHALL CONSIST OF MULCH, ASPEN EXCELSIOR FIBERS, CHIPPED SITE VEGETATION, COCONUT FIBERS, 100% RECYCLABLE FIBERS, OR ANY OTHER ACCEPTABLE MATERIAL EXCLUDING STRAW AND HAY.  
 DAILY INSPECTION SHALL BE MADE BY THE CONTRACTOR AND SILT ACCUMULATION MUST BE REMOVED WHEN DEPTH REACHES 2".  
 CONTRACTOR SHALL MONITOR THE PERFORMANCE OF INLET PROTECTION DURING EACH RAINFALL EVENT AND IMMEDIATELY REMOVE THE INLET PROTECTIONS IF THE STORM WATER BEGINS TO OVERTOP THE CURB.  
 INLET PROTECTIONS SHALL BE REMOVED AS SOON AS THE SOURCE OF SEDIMENT IS STABILIZED.

**TYPICAL INLET SEDIMENT PROTECTION**

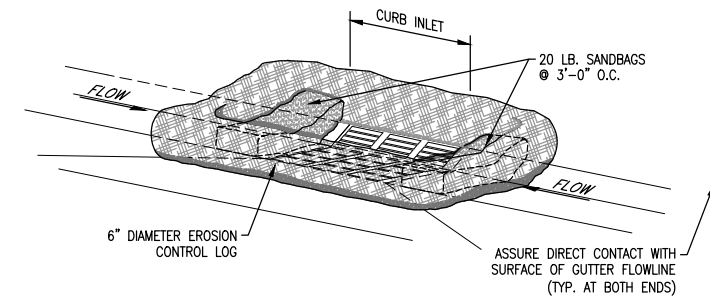

NOTES:  
 EROSION CONTROL LOG CONTAINMENT MESH SHALL BE 100% BIODEGRADABLE, PHOTODEGRADABLE OR RECYCLABLE; AND FILL MATERIAL SHALL CONSIST OF MULCH, ASPEN EXCELSIOR FIBERS, CHIPPED SITE VEGETATION, COCONUT FIBERS, 100% RECYCLABLE FIBERS, OR ANY OTHER ACCEPTABLE MATERIAL EXCLUDING STRAW AND HAY.  
 DAILY INSPECTION SHALL BE MADE BY THE CONTRACTOR AND SILT ACCUMULATION MUST BE REMOVED WHEN DEPTH REACHES 2".  
 CONTRACTOR SHALL MONITOR THE PERFORMANCE OF INLET PROTECTION DURING EACH RAINFALL EVENT AND IMMEDIATELY REMOVE THE INLET PROTECTIONS IF THE STORM WATER BEGINS TO OVERTOP THE CURB.  
 INLET PROTECTIONS SHALL BE REMOVED AS SOON AS THE SOURCE OF SEDIMENT IS STABILIZED.

**CURB INLET SEDIMENT PROTECTION**

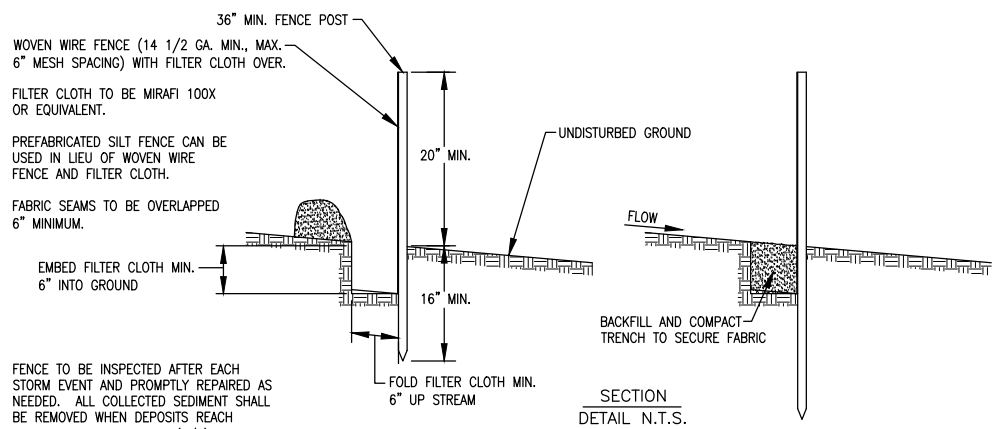
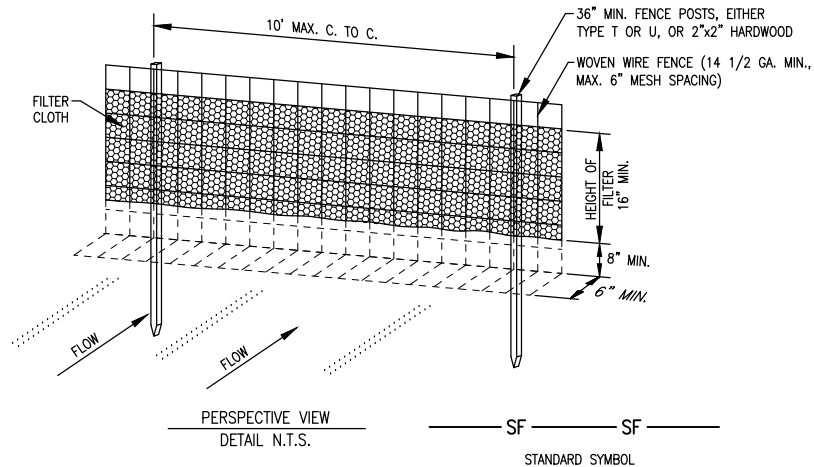

**SILT FENCE**

- SILT FENCING MAY BE UTILIZED SUBJECT TO THE FOLLOWING CONDITIONS:
- MAXIMUM ALLOWABLE SLOPE LENGTHS CONTRIBUTING RUNOFF TO A SILT FENCE SHALL BE IN ACCORDANCE WITH THE FOLLOWING:
 

SLOPE STEEPNESS	MAXIMUM SLOPE LENGTH (FT.)
2H:1V	50
3H:1V	75
4H:1V	125
5H:1V	175
FLATTER THAN 5H:1V	200
  - MAXIMUM DRAINAGE AREA FOR OVERLAND FLOW TO A SILT FENCE SHALL NOT EXCEED 0.5 ACRES PER 100 FEET OF FENCE.

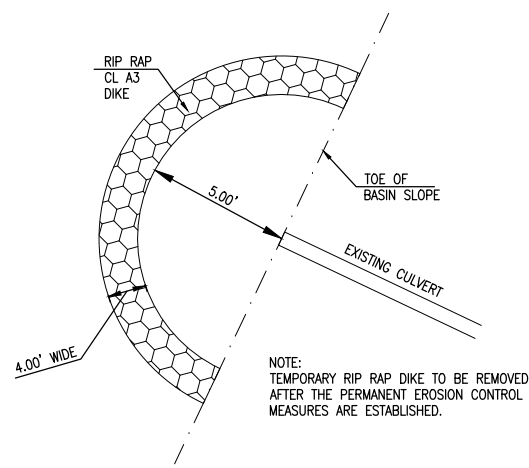

**TEMPORARY SEDIMENT TRAP**

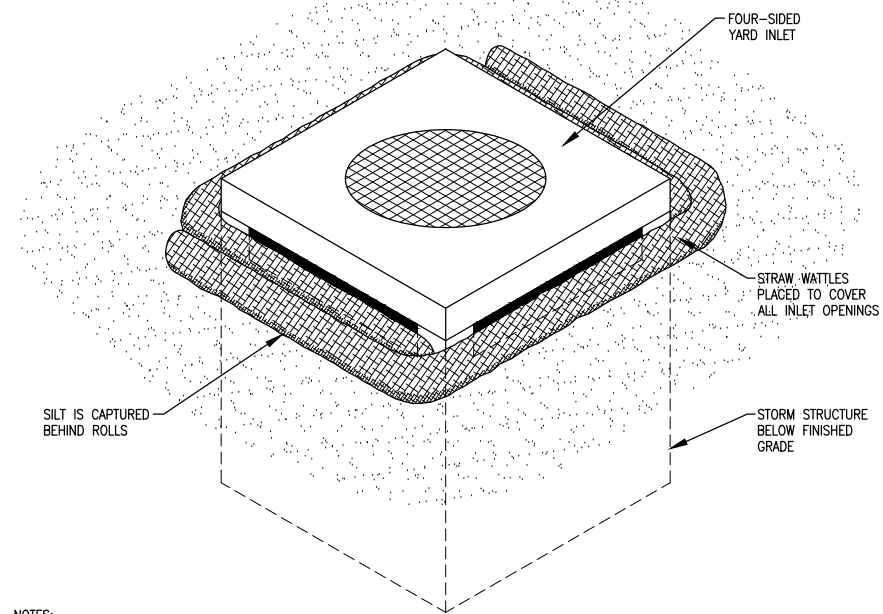

NOTES:  
 1. INSTALLATION TO BE COMPLETED IN ACCORDANCE WITH MANUFACTURER'S SPECIFICATIONS.  
 2. FIBER ROLLS SHOULD BE INSPECTED AFTER EVERY SIGNIFICANT STORM EVENT TO CLEAR AND DISPOSE OF SEDIMENT AND DEBRIS.  
 SPECIFICATIONS:  
 WATTLES SHALL BE A STRAW-FILLED TUBE OF FLEXIBLE NETTING MATERIAL. IT SHALL BE A MACHINE PRODUCED TUBE OF COMPACTED RICE STRAW THAT IS CERTIFIED WEED FREE FORAGE, BY A MANUFACTURER WHOSE PRINCIPAL BUSINESS IS WATTLE MANUFACTURING. THE NETTING SHALL CONSIST OF SEAMLESS, HIGH DENSITY POLYETHYLENE, AND ETHYL VINYL ACETATE AND CONTAIN ULTRAVIOLET LIGHT INHIBITORS. THE WATTLE SHALL HAVE A MINIMUM MASS PER UNIT WEIGHT OF 1.6 LBS./FT., A MINIMUM DIAMETER OF 8.0 - 9.0 INCHES, A MINIMUM NET STRAND THICKNESS OF 0.03 INCHES, A MINIMUM NET KNOT THICKNESS OF 0.055 INCHES AND A MINIMUM NETTING UNIT WEIGHT OF 0.35 OUNCES/FOOT. THE SEDIMENT RETENTION CAPACITY OF THE WATTLE SHALL BE 30 LBS./FOOT. FIBRE CONTENT SHALL BE 100 PERCENT CERTIFIED RICE STRAW WITH A MINIMUM LENGTH OF 3.0.

**AREA INLET SEDIMENT PROTECTION**



CONSULTING ENGINEERING  
 GEOSPATIAL SERVICES

ILLINOIS | SWANSEA  
 WATERLOO  
 EDWARDSVILLE  
 PEORIA

MISSOURI | ST. CHARLES  
 ST. LOUIS

TENNESSEE | NASHVILLE

**THOUVENOT, WADE & MOERCHEN, INC.**

SWANSEA OFFICE  
 4940 OLD COLLINSVILLE ROAD  
 SWANSEA, ILLINOIS  
 62226  
 (618) 624-4488  
 WWW.TWM-INC.COM

PROF. LICENSE	NUMBER
IL PROF. DESIGN FIRM	184-001220
IL PROF. ENGR. CORP.	62-035370
IL PROF. STR. ENGR. CORP.	81-005202
IL PROF. LAND SURV. CORP.	048-000029
MO. PROF. ENGR. CORP.	001528
MO. LAND SURVEYING CORP.	000346
TN. PROF. ENGR. FIRM	8974

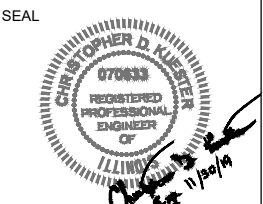

SIGNATURE:  
 DATE SIGNED: JUNE 17, 2019  
 LICENSE EXPIRATION: NOV. 30, 2019

IMPROVEMENT PLANS  
 JUNE 17, 2019

REV.	DATE	DESCRIPTION
△		
△		
△		
△		

DRAWN BY: LEM  
 DESIGNED BY: MJM  
 CHECKED BY: MJM  
 APPROVED BY: MJM  
 PROJECT NO: D01160158B

PROJECT:  
 COUNTRY CLUB HILLS PHASE III  
 CITY OF WATERLOO  
 MONROE COUNTY  
 ILLINOIS

TITLE:  
 EROSION CONTROL DETAILS

P:\160158B\4_CADD - DWG\4-5_Subset\160158B-PLANS-PHASE 3.dwg Plotted By: ckuester

AGENDA REQUEST

(Submit by 12:00 p.m. on Wednesday before the meeting date requested.)

1. Request is made for placement on the agenda for meeting to be held on:  
July 15, 2019  
(Date)
  
2. Description of matter to be placed on agenda:  
Consideration and Action on Purchase of an F150 Pickup Truck from Morrow Bros. Ford, in the amount of \$31,270.00, to replace a 1999 ¾ Ton Pickup Truck.  
_____  
_____  
_____
  
3. Relief or action to be requested:  
Approval.  
_____
  
4. Submittal date: 07/09/19  
  
Submitted by: _____  
Tim Birk, Director of Public Works  
_____  
_____

DISPOSITION

5. _____ Matter to be placed on agenda for meeting date requested.  
  
_____ Matter to be placed on agenda for meeting to be held on _____  
  
_____ Matter referred to _____

  
_____  
Mayor

WWW.MORROWBROTHERSFORDINC.COM

1242 Main Street • Greenfield, IL • 62044

Phone (217) 368-3037 • Fax (217) 368-3517 • Toll Free 1-877-368-3038



**STATE OF ILLINOIS  
F150 TRUCK  
GOVERNMENT PRICING**

ORDERING AGENCY: City of Waterloo

CONTACT PERSON: Tim Birk CELL: 618-781-9430

FORD FLEET # _____ PURCHASE ORDER # _____

QUANTITY: 1 COST EACH: \$ 31,270.00

ADDRESS: 100 West 4th Street

CITY: Waterloo ZIP CODE: 62298 TAX EXEMPT # E9994 -3069 -07

PHONE: 618-939-8600 FAX: 618-939-5415 EMAIL: tbirk@waterloo.il.us  
ext. 221

TOTAL ORDER COST: \$ 31,270.00

SIGNATURE _____ TITLE Director of Public Works

Morrow Brothers Ford Inc.  
1242 Main Street  
Greenfield, IL 62044

Phone # 1-217-368-3037  
Fax # 1-217-368-3517  
Email: [richie@morrowbrothersfordinc.com](mailto:richie@morrowbrothersfordinc.com)

**PLEASE SUBMIT THIS SIGNED FORM WITH ORDER**

***PAYMENT DUE UPON DELIVERY***

AGENDA REQUEST

(Submit by 12:00 p.m. on Wednesday before the meeting date requested.)

1. Request is made for placement on the agenda for meeting to be held on:  
July 15, 2019  
(Date)
  
2. Description of matter to be placed on agenda:  
Consideration and Action on Approval of Visu-Sewer of Missouri, LLC as Low Bidder in the Amount of \$127,671.20 for the 2019 Sewer Lining Project.  
_____  
_____  
_____  
_____
  
3. Relief or action to be requested:  
Approval.  
_____
  
4. Submittal date: 07/09/19  
  
Submitted by: _____  
Tim Birk, Director of Public Works  
_____  
_____

DISPOSITION

5. _____ Matter to be placed on agenda for meeting date requested.  
_____ Matter to be placed on agenda for meeting to be held on _____  
_____ Matter referred to _____

  
_____  
Mayor



2019 Sewer lining  
2:00 p.m. 7/9/19

Greg Patton Insituform 314 409 5069

Johnny Doss Visu-Sewer 800 495 6036

Russ Thomas

City of Waterloo

613-616-9891

John Wietter HMG

618-789-3496

Tim Birk City

1) Insituform Tech. USA, LLC w/ Bid Bond  
Base Bid: 124,206.40 > \$ 27,000 - alt.#1  
Base & alt.#1: 151,206.40

2) Vizusur of MO, LLC w/ Bid Bond  
Base Bid: Unit 102 021.20  
alt. 25,650.00  
Base & Alt. → 127,671.20

3) S.A.K. w/ Bid Bond  
Base: 110,510.00  
alt.#1 39,085.20  
Base & Alt. 149,595.20

D Budget - \$ 150,000.00



AGENDA REQUEST

(Submit by 12:00 p.m. on Wednesday before the meeting date requested.)

1. Request is made for placement on the agenda for meeting to be held on:  
July 15, 2019  
(Date)

2. Description of matter to be placed on agenda:  
Consideration and Action on Special Event Permit Application from Helping  
Strays of Monroe County for a Queen of Hearts Raffle to be conducted at  
Hopskeller Brewing Company on Thursday evenings beginning August 8, 2019.

3. Relief or action to be requested:  
Approval.

4. Submittal date: 07/09/19  
  
Submitted by:  
Bill Dahlkamp, Shelter Director  
Helping Strays of Monroe County

DISPOSITION

5.          Matter to be placed on agenda for meeting date requested.  
         Matter to be placed on agenda for meeting to be held on           
         Matter referred to         

  
_____  
Mayor



**CITY OFFICES**  
100 West Fourth Street  
Waterloo, Illinois 62298  
(618) 939-8600

## SPECIAL EVENT PERMIT APPLICATION

### Instructions to Applicant:

- The following information must be completed and submitted to the City Clerk's Office at the Waterloo City Hall.
- **Application Fee: None**
- Special Event Permit Applications **must be submitted thirty (30) days prior to the date of requested event** to allow for proper time to process with all city departments.
- All damages to property and equipment shall be billed to the applicant and shall be paid by said applicant upon receipt.

1. Event Name / Type: Queen of Hearts Raffle  
Location of Event: Hopskeller Brewing Company
2. Beginning Date / Time: SEE ATTACHMENT #1 Ending Date / Time: _____
3. Organization Name: Humane Society of Monroe County, IL dba Helping Strays of Monroe County  
Mailing Address: 4221 Hanover Road Columbia IL 62236  
Street City State Zip  
Phone Number: (618) 939-7389 Email Address: info@helpingstrays.org  
Not For Profit Status: Yes  No  ID # 04-3734216
4. Person in Charge of Event: Bill Dahlkamp, Shelter Director  
Mailing Address: _____  
Street City State Zip  
Cell Phone Number _____ Email Address: _____
5. Secondary Contact Person: Robert Andress  
Mailing Address: _____  
Street City State Zip  
Cell Phone Number: _____ Email Address: l

**THE FOLLOWING INFORMATION MUST BE PROVIDED BEFORE APPLICATION WILL BE PROCESSED.**

A. **Narrative of Event.** This is a Queen of Hearts Raffle to benefit Helping Strays of Monroe County. The drawings will be held at Hopskeller Brewing Company on Thursday evenings at 7pm, beginning August 8, 2019. Tickets will be sold for \$1 each. The event will have the potential of running through Thursday, August 27, 2020, if no one wins the jackpot before then.

B. **Sketch Plan of Site or Route of Walk/Run** Attached  Not Applicable

C. **Will there be inflatable jumpers/bounce houses or amusement rides:** Yes  No   
• If yes, Proof of Liability Insurance is required. (See Clerk's Office for details.)

D. **Proof of Liability Insurance must be provided and, if the event is held on City property, the City of Waterloo must be named as an additional insured with Comprehensive General Liability limits of not less than \$1,000,000 combined single limit, each occurrence / \$2,000,000 aggregate.**  
Attached

E. **Liquor License information for beer sales (hours of sale):** N/A

G. **Special Needs (i.e. Police, Fire, EMS, Street Dept., Electric)**

Special Event Organizer(s) must also provide for the sanitary collection of all refuse, litter, and garbage generated by patrons attending the event, and removal of all such waste materials from the location of the event in a timely manner.

**Signage**

As part of the approval of this Special Event Permit, temporary signs for said Special Event shall be permitted as provided for in the City Sign Ordinance.

**I agree to abide by the rules and certify that I, on behalf of the applicant or organization, am also authorized to commit that organization, and therefore agree to be financially responsible for any cost and fees that may be incurred by or on behalf of the event to the City of Waterloo. I also understand that acceptance of application should in no way be construed as a final approval/confirmation of this request.**

Bell Dahlkamp Signature of person in charge of event      7/9/19 Date of Submission

*For office use only*

"Special Events Permits" shall go before the City Council for approval.

Approved by City Council: Yes  No  Date _____

Police Department  Fire Department  EMS  Dispatch   
DPW / Street Department (for street closings, signalization, and detour routes)

**EXHIBIT 1**

The following is the date, time, and location at which winning chances will be determined for multiple raffles to be held within a maximum period of one (1) year from the date of the issuance of this raffle license; or for 55 weeks in the case of a Queen of Hearts raffle.

1. Date: August 8,15,27,29 (2019) Time: 7:00pm  
Location: Hopskeller Brewing Company, 116 E. 3rd Street, Waterloo, IL 62298
2. Date: September 5,12,19,26 (2019) Time: 7:00pm  
Location: Hopskeller Brewing Company, 116 E. 3rd Street, Waterloo, IL 62298
3. Date: October 3,10,17,24,31 (2019) Time: 7:00pm  
Location: Hopskeller Brewing Company, 116 E. 3rd Street, Waterloo, IL 62298
4. Date: November 7,14,21,28 (2019) Time: 7:00pm  
Location: Hopskeller Brewing Company, 116 E. 3rd Street, Waterloo, IL 62298
5. Date: December 5,12,19,26 (2019) Time: 7:00pm  
Location: Hopskeller Brewing Company, 116 E. 3rd Street, Waterloo, IL 62298
6. Date: January 2,9,16,23,30 (2020) Time: 7:00pm  
Location: Hopskeller Brewing Company, 116 E. 3rd Street, Waterloo, IL 62298
7. Date: February 6,13,20,27 (2020) Time: 7:00pm  
Location: Hopskeller Brewing Company, 116 E. 3rd Street, Waterloo, IL 62298
8. Date: March 5,12,19,26 (2020) Time: 7:00pm  
Location: Hopskeller Brewing Company, 116 E. 3rd Street, Waterloo, IL 62298
9. Date: April 2,9,16,23,30 (2020) Time: 7:00pm  
Location: Hopskeller Brewing Company, 116 E. 3rd Street, Waterloo, IL 62298
10. Date: May 7,14,21,28 (2020) Time: 7:00pm  
Location: Hopskeller Brewing Company, 116 E. 3rd Street, Waterloo, IL 62298
11. Date: June 4,11,18,25 (2020) Time: 7:00pm  
Location: Hopskeller Brewing Company, 116 E. 3rd Street, Waterloo, IL 62298
12. Date: July 2,9,16,23,30 (2020) Time: 7:00pm  
Location: Hopskeller Brewing Company, 116 E. 3rd Street, Waterloo, IL 62298

**EXHIBIT 1**

The following is the date, time, and location at which winning chances will be determined for multiple raffles to be held within a maximum period of one (1) year from the date of the issuance of this raffle license; or for 55 weeks in the case of a Queen of Hearts raffle.

1. Date: August 6, 13, 20, 27 (2020) Time: 7:00pm  
Location: Hopskeller Brewing Company, 116 E. 3rd Street, Waterloo, IL 62298
2. Date: _____ Time: _____  
Location: _____
3. Date: _____ Time: _____  
Location: _____
4. Date: _____ Time: _____  
Location: _____
5. Date: _____ Time: _____  
Location: _____
6. Date: _____ Time: _____  
Location: _____
7. Date: _____ Time: _____  
Location: _____
8. Date: _____ Time: _____  
Location: _____
9. Date: _____ Time: _____  
Location: _____
10. Date: _____ Time: _____  
Location: _____
11. Date: _____ Time: _____  
Location: _____
12. Date: _____ Time: _____  
Location: _____



AGENDA REQUEST

(Submit by 12:00 p.m. on Wednesday before the meeting date requested.)

1. Request is made for placement on the agenda for meeting to be held on:  
July 15, 2019  
(Date)
  
2. Description of matter to be placed on agenda:  
Consideration and Action on Special Event Permit Application from JV's for the Annual Explore Waterloo event to be held on Friday, Sept. 13, 2019 from 6:00 p.m. to 11:00 p.m. with the closure of Main Street between First Street and the Flower Street alley.  
_____  
_____  
_____
  
3. Relief or action to be requested:  
Approval.  
_____
  
4. Submittal date: 06/19/19  
  
Submitted by: _____  
Jeff Vogt, JV's  
_____  
_____

DISPOSITION

5. _____ Matter to be placed on agenda for meeting date requested.  
_____ Matter to be placed on agenda for meeting to be held on _____  
_____ Matter referred to _____

  
_____  
Mayor

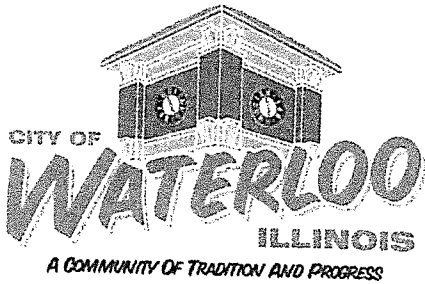

**CITY OFFICES**  
100 West Fourth Street  
Waterloo, Illinois 62298  
(618) 939-8600

## SPECIAL EVENT PERMIT APPLICATION

### Instructions to Applicant:

- The following information must be completed and submitted to the City Clerk's Office at the Waterloo City Hall.
- **Application Fee: None**
- Special Event Permit Applications **must be submitted sixty (60) days prior to the date of requested event** to allow for proper time to process with all city departments.
- All damages to property and equipment shall be billed to the applicant and shall be paid by said applicant upon receipt.
- A **Pre-Event Meeting** will be required prior to approval by City Council.

1. Event Name / Type: Explore Street  
Location of Event: 100 Block of North Main Street
2. Beginning Date / Time: Friday Sept 13 6:00pm Ending Date / Time: FRIDAY Sept 13 11:00
3. Organization Name: _____  
Mailing Address: _____  
Street City State Zip  
Phone Number: _____ Email Address: _____  
Not For Profit Status: Yes  No  ID # _____
4. Person in Charge of Event: JEFF VURT  
Mailing Address: _____  
Street City State Zip  
Cell Phone Number: _____ Email Address: _____
5. Secondary Contact Person: _____  
Mailing Address: _____  
Street City State Zip  
Cell Phone Number: _____ Email Address: _____



**THE FOLLOWING INFORMATION MUST BE PROVIDED BEFORE APPLICATION WILL BE PROCESSED.**

A. Narrative of Event:	The event started as Discover Historic Waterloo held events on 2nd Fridays now called Explore Waterloo
B. Number of People Expected:	200?
C. Sketch Plan of Site or Route of Walk/Run (downtown or Rogers St.) including marked locations of trash cans / dumpster, sanitary facilities, barricades and street closures. Attached <input type="checkbox"/> OVER	
D. Will there be inflatable jumpers/bounce houses or amusement rides: Yes <input type="checkbox"/> No <input checked="" type="checkbox"/>	
• If yes, Proof of Liability Insurance must include inflatables.	
E. Liquor License information for beer sales (hours of sale and license number):	none / A-0047559 Exp 5/31/20 City 08 Ex 6/30/19
F. Special Needs (i.e. Police, Street Dept., Electric - outlets, sound system)	BARRICADES NO ELECTRIC

Proof of Liability Insurance must be provided 14 days after approval or 14 days prior to the event whichever is sooner. If the event is held on City property, the City of Waterloo **must** be named as an additional insured with Comprehensive General Liability limits of not less than \$1,000,000 combined single limit, each occurrence / \$2,000,000 aggregate.  
Received  Date _____

**Special Event Organizer(s) must also provide for the sanitary collection of all refuse, litter, and garbage generated by patrons attending the event, and removal of all such waste materials from the location of the event and surrounding areas, including Courthouse trash cans if applicable, on the day of the event.**

**Signage:** As part of the approval of this Special Event Permit, temporary signs for said Special Event shall be permitted as provided for in the City Sign Ordinance.

I agree to abide by the rules and certify that I, on behalf of the applicant or organization, am also authorized to commit that organization, and therefore agree to be financially responsible for any cost and fees that may be incurred by or on behalf of the event to the City of Waterloo. I also understand that acceptance of application should in no way be construed as a final approval/confirmation of this request.

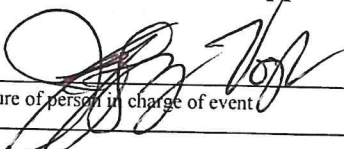
  
 Signature of person in charge of event

6/19/19  
 Date of Submission

*For office use only*

"Special Events Permits" shall go before the City Council for approval.

Approved by City Council: Yes  No  Date _____

Zoning Department <input type="checkbox"/>	Mayor's Office <input type="checkbox"/>	Police Department <input type="checkbox"/>
DPW / Street Department (for street closings, signalization, and detour routes) <input type="checkbox"/>	/	Electric Department <input type="checkbox"/>

TEAS A  
CLASS

Alley (Flower Street)

BAND

OUTSIDE  
BIN

SIDEWALK

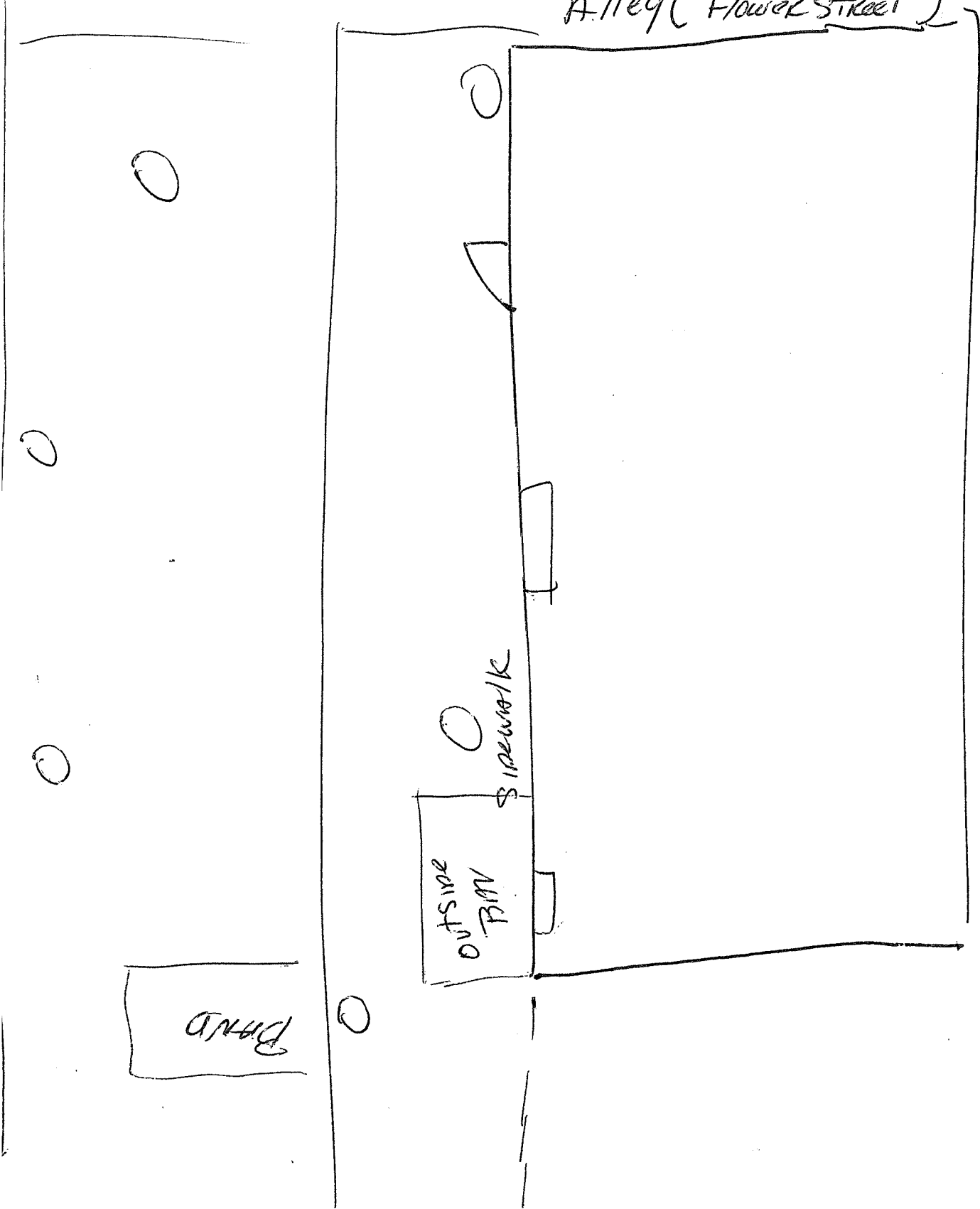

AGENDA REQUEST

(Submit by 12:00 p.m. on Wednesday before the meeting date requested.)

1. Request is made for placement on the agenda for meeting to be held on:  
July 15, 2019  
(Date)
  
2. Description of matter to be placed on agenda:  
Consideration and Action on Special Event Permit Application from Life Network of Southern Illinois for a Walk / Run / Ride to be held on September 21, 2019.  
_____  
_____  
_____
  
3. Relief or action to be requested:  
Approval.  
_____
  
4. Submittal date: 06/20/19  
  
Submitted by: _____  
Debbie Geist, Life Network of Southern Illinois  
_____  
_____

DISPOSITION

5. _____ Matter to be placed on agenda for meeting date requested.  
_____ Matter to be placed on agenda for meeting to be held on _____  
_____ Matter referred to _____

  
_____  
Mayor

A Christ-centered ministry committed to upholding the sanctity of human life.



June 21, 2019

To Whom It May Concern:

This is an Agenda Request to the Waterloo City Council on behalf of Life Network of Southern Illinois Pregnancy Resource Center.

I am requesting approval for the proposed route for the **5K Run/1.8 Mile Walk** that will benefit Life Network scheduled for Saturday, September 21st, 2019. The 5K Run is scheduled to begin at 9:00 a.m. and the 1.8 Mile Walk at approximately 9:05 a.m. The attached sheet details the route for the runners and walkers separately. We are also offering a 15- and 30-mile bike ride but we only anticipate around 15 to 25 bikers for that event and most of it will take place outside the City limits. (see attached maps)

This event is one of two major fundraisers that Life Network relies on to help meet our operating budget for the following year.

If you have any questions, please contact me at 939-4224.

Thank you for your consideration in this matter.

Sincerely,

Debbie Geist

Executive Director  
Life Network of Southern Illinois  
dgeist@htc.net



## SPECIAL EVENT PERMIT APPLICATION

### Instructions to Applicant:

- The following information must be completed and submitted to the City Clerk's Office at the Waterloo City Hall.
- **Application Fee: None**
- Special Event Permit Applications **must be submitted sixty (60) days prior to the date of requested event** to allow for proper time to process with all city departments.
- All damages to property and equipment shall be billed to the applicant and shall be paid by said applicant upon receipt.
- A **Pre-Event Meeting** will be required prior to approval by City Council.

1. Event Name / Type: 5K Run • Walk • Bike Ride  
Location of Event: Life Network of Southern IL
2. Beginning Date / Time: 9-21-19 @ 7:30 Ending Date / Time: 9-21-19 - NOON
3. Organization Name: Life Network of Southern Illinois  
Mailing Address: 722 N. Market St - Waterloo, IL 62298  
Street City State Zip  
Phone Number: 618-939-4224 Email Address: _____  
Not For Profit Status: Yes  No _____ ID # 37-1293441
4. Person in Charge of Event: Debbie Geist  
Mailing Address: Same as above  
Street City State Zip  
Cell Phone Number: _____ Email Address: _____
5. Secondary Contact Person: Allison Kirkpatrick  
Mailing Address: Same  
Street City State Zip  
Cell Phone Number: _____ Email Address: _____



**THE FOLLOWING INFORMATION MUST BE PROVIDED BEFORE APPLICATION WILL BE PROCESSED.**

A. Narrative of Event:	5K RUN / 2 mile Walk / 15+30 mile ride Activities for Kids - pony rides - food ALL @ our location
B. Number of People Expected:	80 For Run / 150 Walk / 25 Ride
C. Sketch Plan of Site or Route of Walk/Run (downtown or Rogers St.) including marked locations of trash cans / dumpster, sanitary facilities, barricades and street closures.	Attached <input checked="" type="checkbox"/>
D. Will there be inflatable jumpers/bounce houses or amusement rides:	Yes <input type="checkbox"/> No <input checked="" type="checkbox"/> • If yes, Proof of Liability Insurance must include inflatables.
E. Liquor License information for beer sales (hours of sale and license number):	
F. Special Needs (i.e. Police, Street Dept., Electric – outlets, sound system)	We will supply Volunteers @ Intersections Police for 5K portion would be appreciated

Proof of Liability Insurance must be provided 14 days after approval or 14 days prior to the event whichever is sooner. If the event is held on City property, the City of Waterloo **must** be named as an additional insured with Comprehensive General Liability limits of not less than \$1,000,000 combined single limit, each occurrence / \$2,000,000 aggregate.

Received  Date _____

**Special Event Organizer(s) must also provide for the sanitary collection of all refuse, litter, and garbage generated by patrons attending the event, and removal of all such waste materials from the location of the event and surrounding areas, including Courthouse trash cans if applicable, on the day of the event.**

**Signage:** As part of the approval of this Special Event Permit, temporary signs for said Special Event shall be permitted as provided for in the City Sign Ordinance.

I agree to abide by the rules and certify that I, on behalf of the applicant or organization, am also authorized to commit that organization, and therefore agree to be financially responsible for any cost and fees that may be incurred by or on behalf of the event to the City of Waterloo. I also understand that acceptance of application should in no way be construed as a final approval/confirmation of this request.

 _____  
Signature of person in charge of event

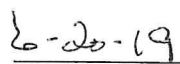
 _____  
Date of Submission

*For office use only*

"Special Events Permits" shall go before the City Council for approval.

Approved by City Council: Yes  No  Date _____

Zoning Department <input type="checkbox"/>	Mayor's Office <input type="checkbox"/>	Police Department <input type="checkbox"/>
DPW / Street Department (for street closings, signalization, and detour routes) <input type="checkbox"/>	/	Electric Department <input type="checkbox"/>



# LIFE NETWORK of Southern Illinois WALK RUN RIDE

SATURDAY, SEPTEMBER 21, 2019  
722 N. Market St., Waterloo IL

BALLOON  
ARTIST

## WALK

8:00 AM REGISTRATION  
9:05 AM 2 MILE WALK START  
\$20 On or before 08/16/2019**  
\$25 After 08/16/2019

PETTING  
ZOO

FOOD

## 5K RUN

8:00 AM REGISTRATION  
9:00 AM 5K RUN START  
\$30 On or before 08/16/2019**  
\$35 After 08/16/2019

PONY RIDES

MUSIC

## RIDE

7:00 AM REGISTRATION  
7:30 AM 30 MILE RIDE START  
8:00 AM 15 MILE RIDE START  
\$20 On or before 08/16/2019**  
\$25 After 08/16/2019

**P** at THE BEACON  
PARKING

ONLINE REGISTRATION  
<http://supportmylifenet.com>  
or  
[Facebook.com/  
lifenetworkofsoill](https://www.facebook.com/lifenetworkofsoill)

**PRE-REGISTRATION  
GUARANTEES  
SWAG BAG & SHIRT!!**  
**Pre-Register By  
Friday, August 16, 2019**

**WANT TO RUN, WALK OR RIDE FOR FREE??**

**GET SPONSORS TO SUPPORT YOU!!**

\$100 IN SPONSORSHIP GUARANTEES NO REGISTRATION FEE AND HELPS SAVE BABIES LIVES!!

For more information:

Go to the Events tab on our website at <http://supportmylifenet.com> *  
[Facebook.com/lifenetworkofsoill](https://www.facebook.com/lifenetworkofsoill) * 618.939.4224

# LIFE NETWORK 2018 WALK ROUTE

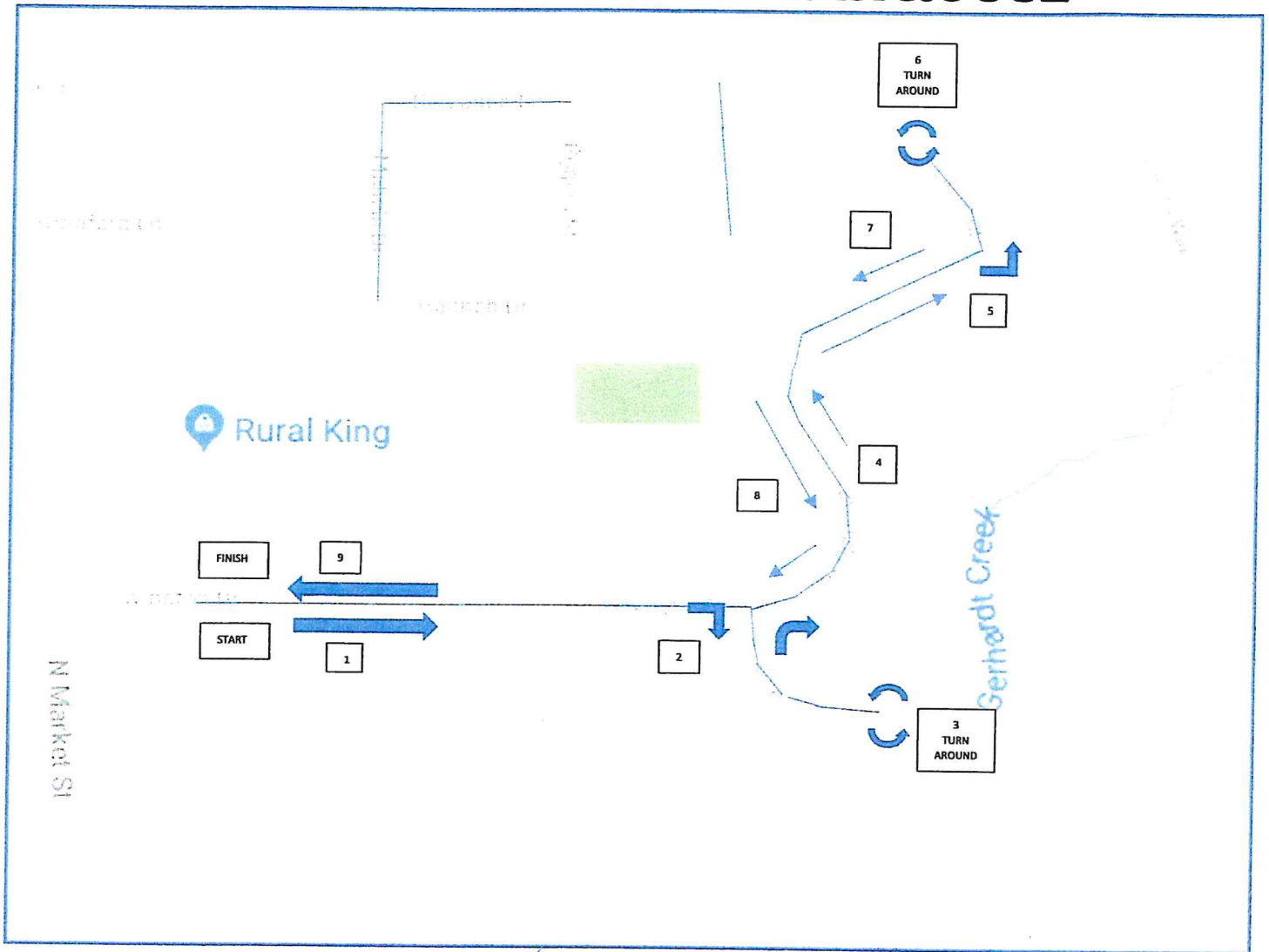

- ★ Begin on Covington Dr. and continue on Covington Dr. past Rogers St.
- ➡ Right on Louise Ln. Turn around in cul-de-sac
- ➡ Right onto Covington Dr.- Continue until you reach Ernst Ct.
- ⬅ Turn left on Ernst Ct. Turn around in cul-de-sac.
- ➡ Turn right on Covington Drive-Continue on Covington Dr., past Rogers St., to Finish Line



# LIFE NETWORK 2018 5K ROUTE

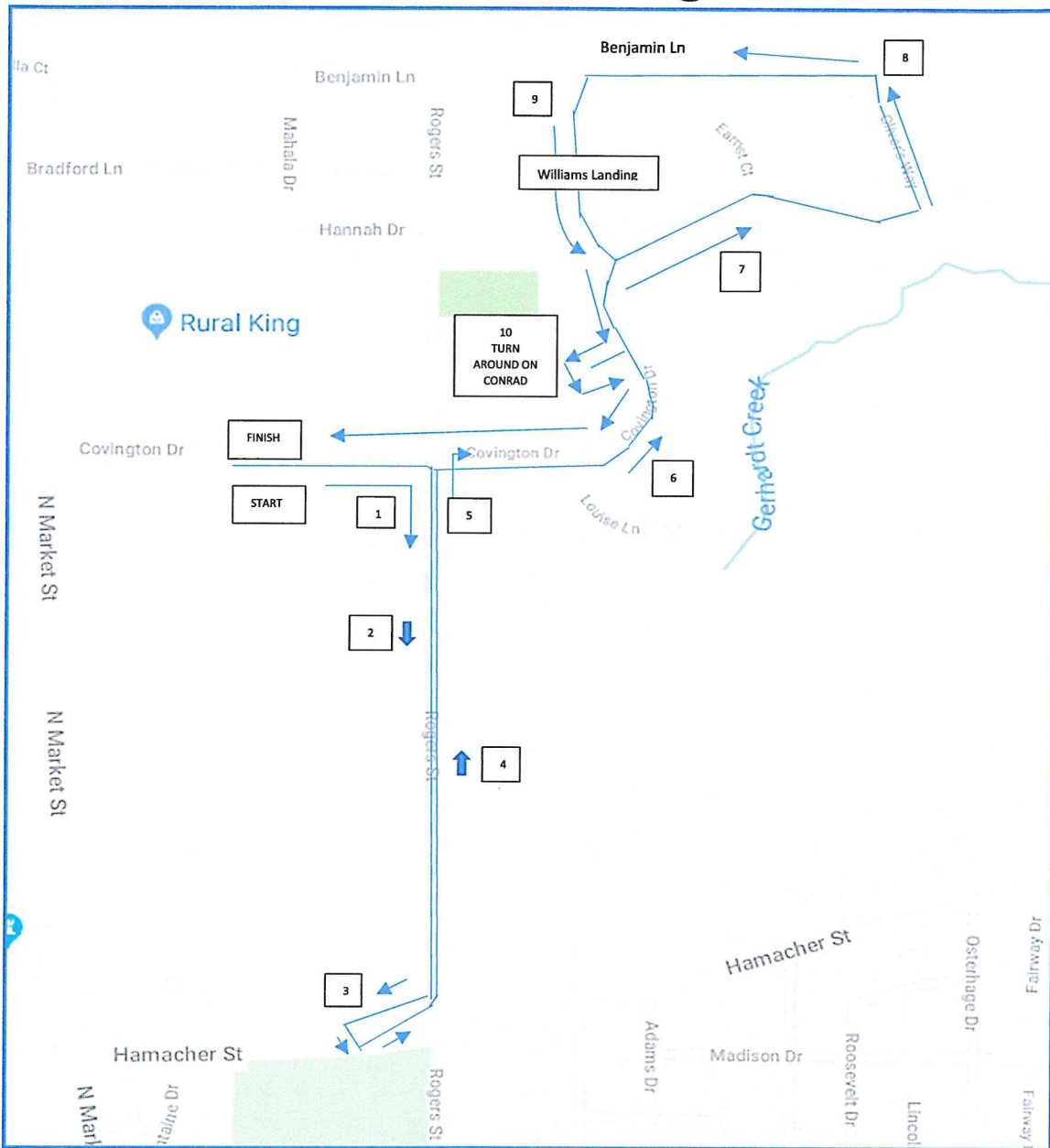

- ★ Begin on Covington Drive between O'Reilly Parking Lot and Lighthouse Learning Center
- ↑ Right onto Rogers Street
- ↻ Turn slight right into parking lot of Zahnow and follow loop back to Rogers Street
- ← Turn left on Rogers Street
- Right onto Covington Drive Head East on Covington Drive
- ← Turn left on Oliver's Way
- ← Turn left on Benjamin Lane
- ← Turn left on William's Landing
- ↻ Turn right on Conrad-go around cul-de-sac
- Turn right on William's Landing
- Turn right on Covington Drive-Continue on Covington to Finish Line

## **30 MILE COURSE**

START at Covington Dr.

LEFT at Rogers St. – Rogers becomes Country Club Ln.

LEFT at Gilmore Lakes Rd. Stay on this road (there will be a number of turns- LEFT on Kelm, RIGHT on Gilmore Lakes) until it becomes Ee Rd.

RIGHT on Lake Gilmore Rd.

LEFT on Bohleysville Rd.

CONTINUE on Triple Lakes Rd. Road will veer left then right.

RIGHT on Kropp Rd which will turn into W. Washington St.

LEFT on Cedar St.

RIGHT on Blackburn Manor

LEFT on N. Polk- turns into Saeger Rd.

RIGHT on Kalbfleisch Dr. to park for WATER STATION

Turn around and head back to Saeger/N. Polk

RIGHT on W. Elm St.

LEFT on S. Veteran Dr. –turns into Werner which will veer left

RIGHT on Saxtown Rd.

LEFT on Bohleysville Rd. (road will veer to right)

Veers left at Dori Ln.-briefly on Lower Saxtown Rd.

RIGHT to continue on Bohleysville Rd.- turns into Floraville Rd.

LEFT on Kopp Rd. which will veer left then right

RIGHT on Konarcik Rd. which will turn into E. 4th St.

RIGHT on Rogers St.

LEFT on Covington

RETURN to LifeNetwork

31.5 miles

WATER STATION

MILLSTADT

VILLAGE PARK

↳ Kalbfleisch Dr.

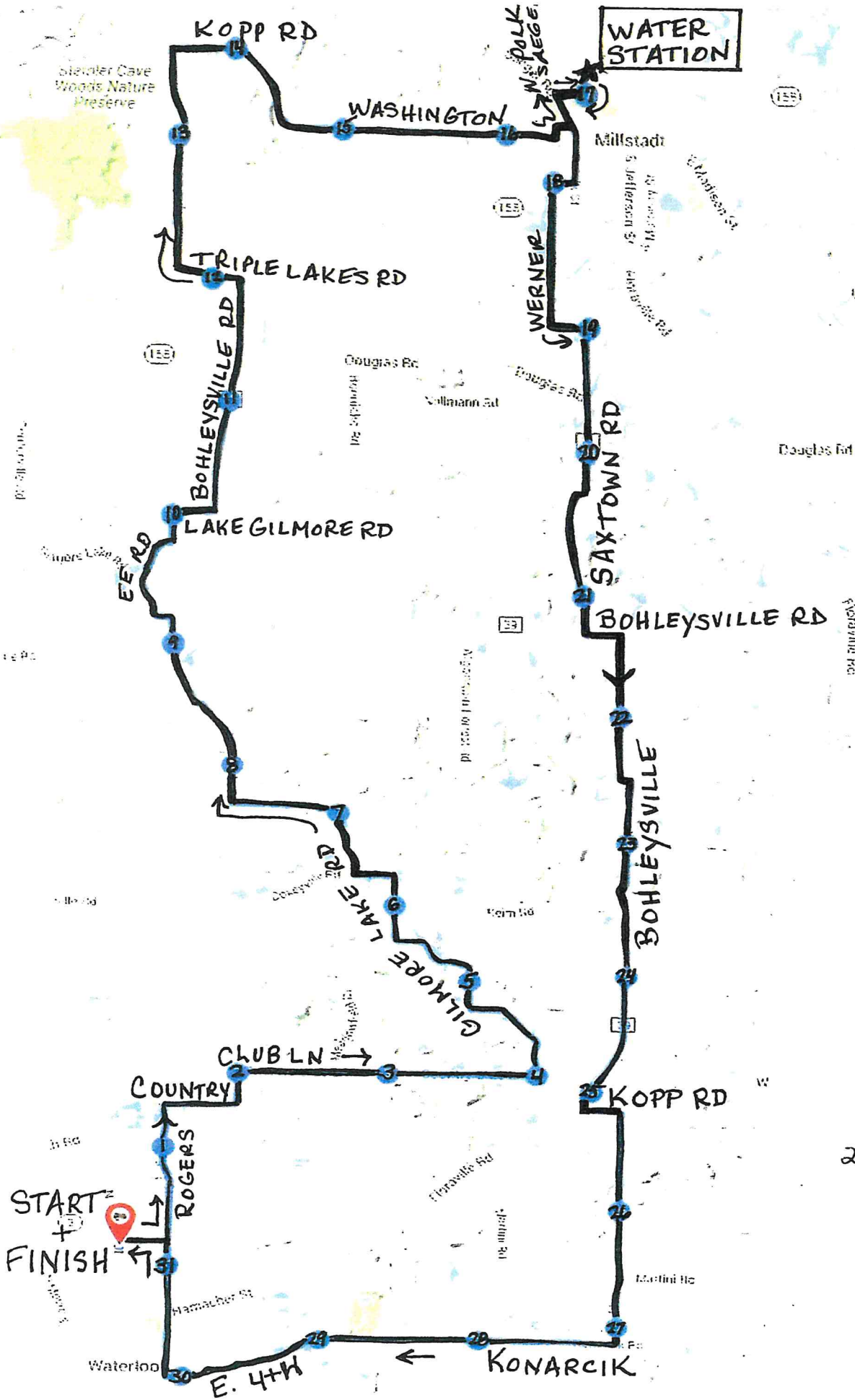

2016 Life Network

## 15.2 MILE COURSE

START – Covington Dr.

LEFT on Rogers St.

Rogers St. turns into Country Club Ln – Continue Straight

LEFT on Gilmore Lake Rd.

LEFT at 5 mile marker – will continue on Gilmore Lake Rd.

RIGHT on Keim Rd.

RIGHT on Bohleysville Rd. (this turns into Floraville Rd.)

LEFT on Kopp Rd (cross over Kopp Creek & go straight at Martini Rd.)

RIGHT on Konarcik Rd which turns into E. 4th St

RIGHT on Rogers St.

LEFT on Covington Dr.

Return back to Life Network

# 15.2 MILE LOOP

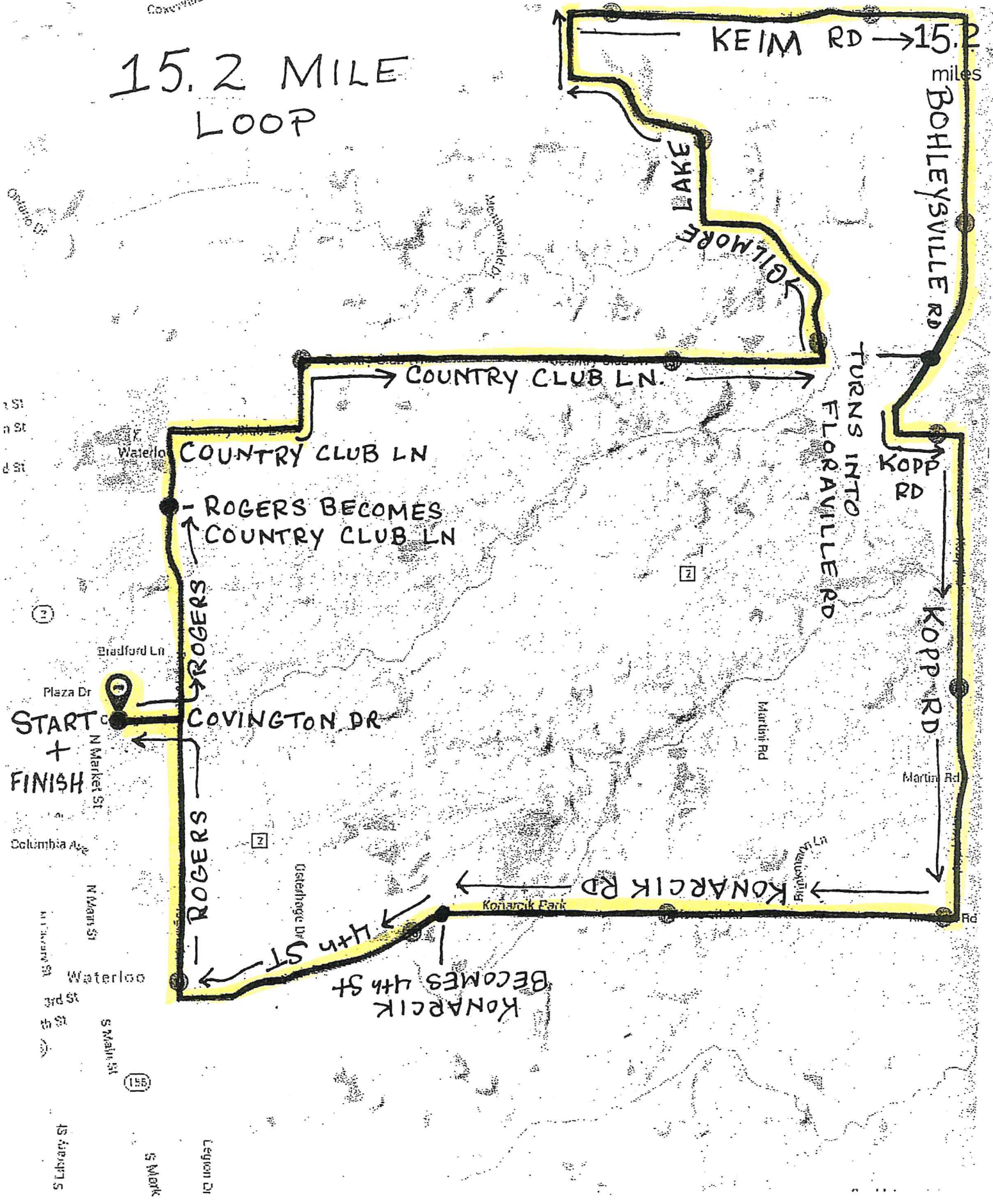



AGENDA REQUEST

(Submit by 12:00 p.m. on Wednesday before the meeting date requested.)

1. Request is made for placement on the agenda for meeting to be held on:  
July 15, 2019  
(Date)
  
2. Description of matter to be placed on agenda:  
Consideration and Action on Special Event Permit Application from the  
WCUSD#5 for their Annual Bulldog Color Run to be held on September 28, 2019  
with partial closures of Fourth, Rogers, First and Hamacher Streets.  
_____  
_____  
_____
  
3. Relief or action to be requested:  
Approval.  
_____  
_____
  
4. Submittal date: 06/19/19  
  
Submitted by: _____  
Jessica Washausen, WCUSD#5  
_____  
_____

DISPOSITION

5. _____ Matter to be placed on agenda for meeting date requested.  
_____ Matter to be placed on agenda for meeting to be held on _____  
_____ Matter referred to _____

  
_____  
Mayor



CITY OFFICES  
100 West Fourth Street  
Waterloo, Illinois 62298  
(618) 939-8600

## SPECIAL EVENT PERMIT APPLICATION

### Instructions to Applicant:

- The following information must be completed and submitted to the City Clerk's Office at the Waterloo City Hall.
- **Application Fee: None**
- Special Event Permit Applications **must be submitted sixty (60) days prior to the date of requested event** to allow for proper time to process with all city departments.
- All damages to property and equipment shall be billed to the applicant and shall be paid by said applicant upon receipt.
- A **Pre-Event Meeting** will be required prior to approval by City Council.

- Event Name / Type: Bulldog Color Run  
Location of Event: Gardner Soccer Fields & Roads Around Schools
- Beginning Date / Time: Sept 28, 2019 Ending Date / Time: Sept 28, 2019
- Organization Name: WCUSD 5  
Mailing Address: 302 Bellefontaine Waterloo, IL 62298  
Street City State Zip  
Phone Number: 618-939-3060 Email Address: jwashausen@wcsd5.net  
Not For Profit Status: Yes  No  ID # E9994-2941-07
- Person in Charge of Event: Jessica Washausen  
Mailing Address: 1 Ed Gardner Place Waterloo, IL 62298  
Street City State Zip  
Cell Phone Number: _____ Email Address: jwashausen@wcsd5.net
- Secondary Contact Person: Julie Deptula  
Mailing Address: 1 Ed Gardner Place Waterloo, IL 62298  
Street City State Zip  
Cell Phone Number: _____ Email Address: jdeptula@wcsd5.net

**THE FOLLOWING INFORMATION MUST BE PROVIDED BEFORE APPLICATION WILL BE PROCESSED.**

A. Narrative of Event:	4 th Annual Bulldog Color Run - Students, parents, staff, & community members will run/walk around the 4 "in town" schools. They will be sprayed with color.
B. Number of People Expected:	500
C. Sketch Plan of Site or Route of Walk/Run (downtown or Rogers St.) including marked locations of trash cans / dumpster, sanitary facilities, barricades and street closures. Attached <input checked="" type="checkbox"/>	
D. Will there be inflatable jumpers/bounce houses or amusement rides: Yes <input type="checkbox"/> No <input checked="" type="checkbox"/> • If yes, Proof of Liability Insurance must include inflatables.	
E. Liquor License information for beer sales (hours of sale and license number):	N/A
F. Special Needs (i.e. Police, Street Dept., Electric – outlets, sound system)	We will need the streets blocked off for the runners.

Proof of Liability Insurance must be provided 14 days after approval or 14 days prior to the event whichever is sooner. If the event is held on City property, the City of Waterloo **must** be named as an additional insured with Comprehensive General Liability limits of not less than \$1,000,000 combined single limit, each occurrence / \$2,000,000 aggregate.  
Received  Date _____

**Special Event Organizer(s) must also provide for the sanitary collection of all refuse, litter, and garbage generated by patrons attending the event, and removal of all such waste materials from the location of the event and surrounding areas, including Courthouse trash cans if applicable, on the day of the event.**

**Signage:** As part of the approval of this Special Event Permit, temporary signs for said Special Event shall be permitted as provided for in the City Sign Ordinance.

I agree to abide by the rules and certify that I, on behalf of the applicant or organization, am also authorized to commit that organization, and therefore agree to be financially responsible for any cost and fees that may be incurred by or on behalf of the event to the City of Waterloo. I also understand that acceptance of application should in no way be construed as a final approval/confirmation of this request.

  
 Signature of person in charge of event _____ Date of Submission 6/19/19

*For office use only*

"Special Events Permits" shall go before the City Council for approval

Approved by City Council: Yes  No  Date _____

Zoning Department <input type="checkbox"/>	Mayor's Office <input type="checkbox"/>	Police Department <input type="checkbox"/>
DPW / Street Department (for street closings, signalization, and detour routes) <input type="checkbox"/>	/ Electric Department <input type="checkbox"/>	





Course Master

AGENDA REQUEST

(Submit by 12:00 p.m. on Wednesday before the meeting date requested.)

1. Request is made for placement on the agenda for meeting to be held on:  
July 15, 2019  
(Date)
  
2. Description of matter to be placed on agenda:  
Consideration and Action on Special Event Permit Application from LifechurchX  
for Biker Sunday to be held on September 29, 2019, from 7:00 a.m. to 3:00 p.m.,  
with the closure of Main Street between Mill and Third Streets.  
_____  
_____  
_____
  
3. Relief or action to be requested:  
Approval.  
_____  
_____
  
4. Submittal date: 06/20/19  
  
Submitted by: _____  
Pastor Matt Heck, LifechurchX  
_____  
_____

DISPOSITION

5. _____ Matter to be placed on agenda for meeting date requested.  
_____ Matter to be placed on agenda for meeting to be held on _____  
_____ Matter referred to _____

  
_____  
Mayor



**CITY OFFICES**  
100 West Fourth Street  
Waterloo, Illinois 62298  
(618) 939-8600

## SPECIAL EVENT PERMIT APPLICATION

**Instructions to Applicant:**

- The following information must be completed and submitted to the City Clerk's Office at the Waterloo City Hall.
- **Application Fee: None**
- Special Event Permit Applications **must be submitted thirty (30) days prior to the date of requested event** to allow for proper time to process with all city departments.
- All damages to property and equipment shall be billed to the applicant and shall be paid by said applicant upon receipt.

1. Event Name / Type: Biker Sunday  
Location of Event: Bandstand
2. Beginning Date / Time: Sun. 9/29 / 7 AM Ending Date / Time: Sun. 9/29 / 3pm
3. Organization Name: Lifechurch*  
Mailing Address: 400 Park Street, Waterloo, IL 62298  
Street City State Zip  
Phone Number: 618-939-0228 Email Address: lisa@lifechurchx.com  
Not For Profit Status: Yes  No  ID # 81-1490500
4. Person in Charge of Event: Pastor Matt Heck  
Mailing Address: 400 Park Street, Waterloo, IL 62298  
Street City State Zip  
Cell Phone Number: _____ Email Address: matt@lifechurchx.com
5. Secondary Contact Person: LISA ROSS  
Mailing Address: 400 Park Street, Waterloo, IL 62298  
Street City State Zip  
Cell Phone Number: _____ Email Address: Lisa@lifechurchx.com



**THE FOLLOWING INFORMATION MUST BE PROVIDED BEFORE APPLICATION WILL BE PROCESSED.**

A. Narrative of Event. Lifechurch* is hosting "Biker Sunday"  
(approx 300 people) on the Bandstand. We're requesting  
street closure for tables + chairs for lunch (catered by  
shorty's). We will also have a velcro wall and  
"cliff dive" for the kids, professionally setup, staffed,  
and insured.

B. Sketch Plan of Site or Route of Walk/Run Attached  Not Applicable

C. Will there be inflatable jumpers/bounce houses or amusement rides: Yes  No   
 • If yes, Proof of Liability Insurance is required. (See Clerk's Office for details.) "Cliff Dive"  
(will provide proof of insurance) "Velcro Wall"

D. Proof of Liability Insurance must be provided and, if the event is held on City property, the City of Waterloo must be named as an additional insured with Comprehensive General Liability limits of not less than \$1,000,000 combined single limit, each occurrence / \$2,000,000 aggregate.  
 Attached  To be faxed by Countrywide Insurance

E. Liquor License information for beer sales (hours of sale): NIA

G. Special Needs (i.e. Police, Fire, EMS, Street Dept., Electric) Please close  
off South Main Street between  
West Mill Street and West 3rd Street

Special Event Organizer(s) must also provide for the sanitary collection of all refuse, litter, and garbage generated by patrons attending the event, and removal of all such waste materials from the location of the event in a timely manner.

**Signage**

As part of the approval of this Special Event Permit, temporary signs for said Special Event shall be permitted as provided for in the City Sign Ordinance.

**I agree to abide by the rules and certify that I, on behalf of the applicant or organization, am also authorized to commit that organization, and therefore agree to be financially responsible for any cost and fees that may be incurred by or on behalf of the event to the City of Waterloo. I also understand that acceptance of application should in no way be construed as a final approval/confirmation of this request.**

Matt Deek  
 Signature of person in charge of event

6/20/19  
 Date of Submission

*For office use only*

"Special Events Permits" shall go before the City Council for approval.

Approved by City Council: Yes  No  Date _____

Police Department  Fire Department  EMS  Dispatch   
 DPW / Street Department (for street closings, signalization, and detour routes)

AGENDA REQUEST

(Submit by 12:00 p.m. on Wednesday before the meeting date requested.)

1. Request is made for placement on the agenda for meeting to be held on:  
July 15, 2019  
(Date)
  
2. Description of matter to be placed on agenda:  
Consideration and Action on Special Event Permit Application from the SPPCS  
PTO for their Annual PumpkinFest 5K / 10K to be held on October 12, 2019 from  
6:00 a.m. to 11:00 a.m.
  
3. Relief or action to be requested:  
Approval.
  
4. Submittal date: 05/16/19  
  
Submitted by:  
Audrey Brown, SPPCS PTO

DISPOSITION

5.          Matter to be placed on agenda for meeting date requested.  
         Matter to be placed on agenda for meeting to be held on           
         Matter referred to

  
_____  
Mayor





**CITY OFFICES**  
 100 West Fourth Street  
 Waterloo, Illinois 62298  
 (618) 939-8600

## SPECIAL EVENT PERMIT APPLICATION

**Instructions to Applicant:**

- The following information must be completed and submitted to the City Clerk's Office at the Waterloo City Hall.
- **Application Fee: None**
- Special Event Permit Applications **must be submitted sixty (60) days prior to the date of requested event** to allow for proper time to process with all city departments.
- All damages to property and equipment shall be billed to the applicant and shall be paid by said applicant upon receipt.
- A **Pre-Event Meeting** will be required prior to approval by City Council.

---

1. Event Name / Type: PumpkinFest 5K/10K  
 Location of Event: City of Waterloo

2. Beginning Date / Time: Sat. Oct. 12th 6am Ending Date / Time: Sat. Oct. 12th 11am

3. Organization Name: SPPCS PTO  
 Mailing Address: 217 W 3rd St. Waterloo IL 62298  
Street City State Zip  
 Phone Number: 618 939 7217 Email Address: abrown@sppswaterloo.com  
 Not For Profit Status: Yes  No  ID # 37-0073537

4. Person in Charge of Event: Amarj Brown  
 Mailing Address: 217 W 3rd St. Waterloo IL 62298  
Street City State Zip  
 Cell Phone Number: _____ Email Address: abrown@sppswaterloo.com

5. Secondary Contact Person: _____  
 Mailing Address: _____  
Street City State Zip  
 Cell Phone Number: _____ Email Address: _____

**THE FOLLOWING INFORMATION MUST BE PROVIDED BEFORE APPLICATION WILL BE PROCESSED.**

A. Narrative of Event:	Fundraiser run/walk for the SPES PTO
B. Number of People Expected:	200
C. Sketch Plan of Site or Route of Walk/Run (downtown or Rogers St.) including marked locations of trash cans / dumpster, sanitary facilities, barricades and street closures.	Attached <input checked="" type="checkbox"/>
D. Will there be inflatable jumpers/bounce houses or amusement rides: Yes <input type="checkbox"/> No <input checked="" type="checkbox"/>	• If yes, Proof of Liability Insurance must include inflatables.
E. Liquor License information for beer sales (hours of sale and license number):	NO
F. Special Needs (i.e. Police, Street Dept., Electric – outlets, sound system)	possible police / Road assistance

Proof of Liability Insurance must be provided 14 days after approval or 14 days prior to the event whichever is sooner. If the event is held on City property, the City of Waterloo **must** be named as an additional insured with Comprehensive General Liability limits of not less than \$1,000,000 combined single limit, each occurrence / \$2,000,000 aggregate.

Received  Date _____

**Special Event Organizer(s) must also provide for the sanitary collection of all refuse, litter, and garbage generated by patrons attending the event, and removal of all such waste materials from the location of the event and surrounding areas, including Courthouse trash cans if applicable, on the day of the event.**

**Signage:** As part of the approval of this Special Event Permit, temporary signs for said Special Event shall be permitted as provided for in the City Sign Ordinance.

I agree to abide by the rules and certify that I, on behalf of the applicant or organization, am also authorized to commit that organization, and therefore agree to be financially responsible for any cost and fees that may be incurred by or on behalf of the event to the City of Waterloo. I also understand that acceptance of application should in no way be construed as a final approval/confirmation of this request.

  
 Signature of person in charge of event

5/6/19  
 Date of Submission

*For office use only*

"Special Events Permits" shall go before the City Council for approval.

Approved by City Council: Yes  No  Date _____

Zoning Department <input type="checkbox"/>	Mayor's Office <input type="checkbox"/>	Police Department <input type="checkbox"/>
DPW / Street Department (for street closings, signalization, and detour routes) <input type="checkbox"/>	/ Electric Department <input type="checkbox"/>	

Rte 1

Rural Rte 7

Ket St

Gibault High School

1

2

Waterloo Dr

Ward Ave

Grand Ave

Monroe St

Columbia Ave

Veterans

Waterlc Hig

Mockingbird Ln

1 Lake Dr

Illinois Ave

Illinois Ave

3

Mueller Ln  
Westview Pl

Rau St

N Church St

W 1st S

Oak Creek Ln

Saints Peter and Paul Catholic School

3

Wate

Cre

w 4th St

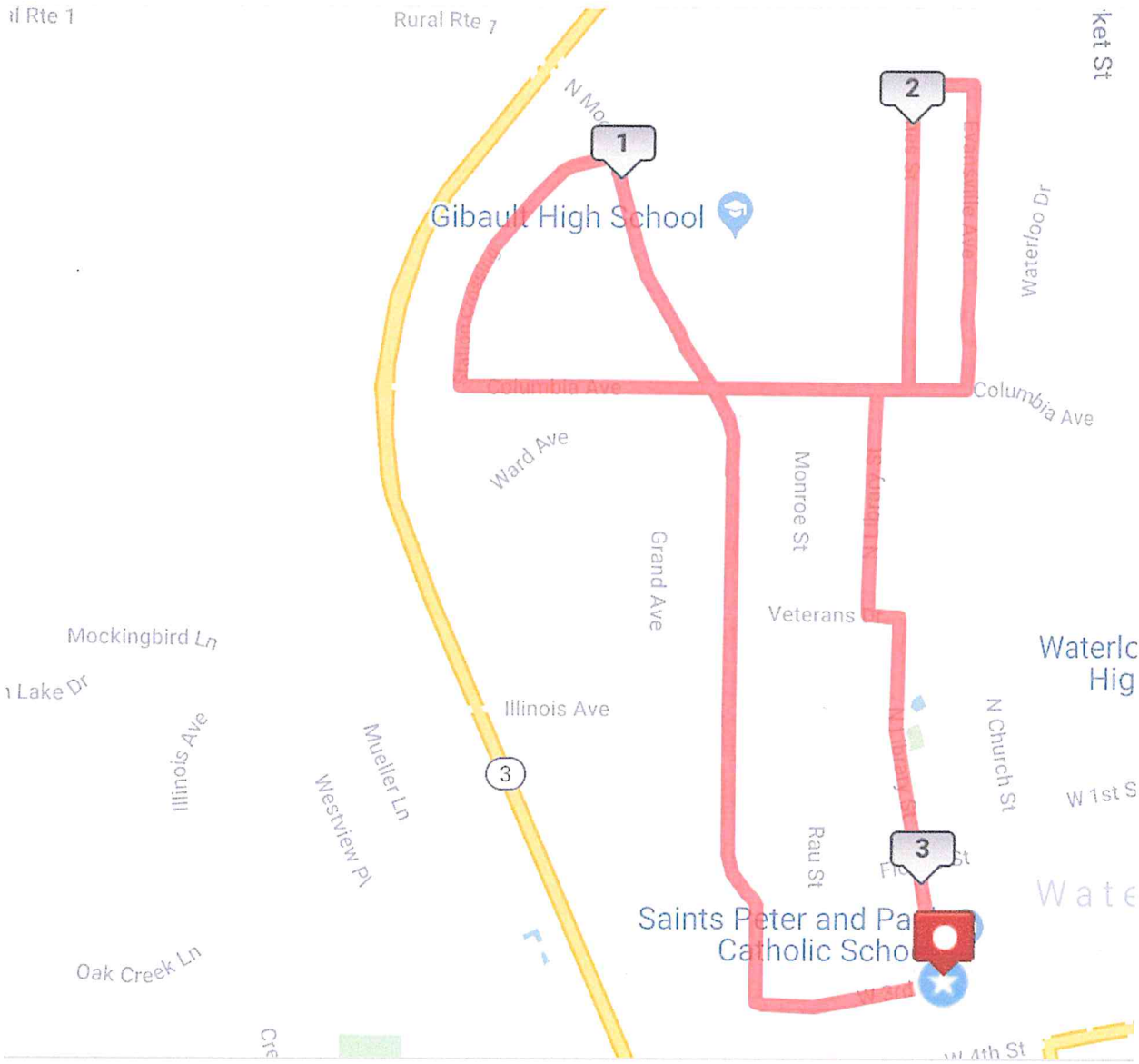

AGENDA REQUEST

(Submit by 12:00 p.m. on Wednesday before the meeting date requested.)

1. Request is made for placement on the agenda for meeting to be held on:  
July 15, 2019  
(Date)
  
2. Description of matter to be placed on agenda:  
Consideration and Action on Special Event Permit Application from the City of Waterloo for PumpkinFest to be held in Downtown Waterloo on October 12, 2019, from 7:30 a.m. to 5:00 p.m., with the closure of Main Street, Mill Street and Third Street around the Courthouse Square, and to include temporary signage.  
_____  
_____
  
3. Relief or action to be requested:  
Approval.  
_____
  
4. Submittal date: 06/27/19  
  
Submitted by: _____  
Mayor Tom Smith  
_____  
_____

DISPOSITION

5. _____ Matter to be placed on agenda for meeting date requested.  
_____ Matter to be placed on agenda for meeting to be held on _____  
_____ Matter referred to _____

  
_____  
Mayor





**CITY OFFICES**  
100 West Fourth Street  
Waterloo, Illinois 62298  
(618) 939-8600

## SPECIAL EVENT PERMIT APPLICATION

### **Instructions to Applicant:**

- The following information must be completed and submitted to the City Clerk's Office at the Waterloo City Hall.
- **Application Fee: None**
- Special Event Permit Applications **must be submitted thirty (30) days prior to the date of requested event** to allow for proper time to process with all city departments.
- All damages to property and equipment shall be billed to the applicant and shall be paid by said applicant upon receipt.

- 
1. Event Name / Type: PumpkinFest  
Location of Event: Downtown Waterloo
  
  2. Beginning Date / Time: 10/12/2019 7:30 a.m. Ending Date / Time: 10/12/2019 5:00 p.m.
  
  3. Organization Name: City of Waterloo  
Mailing Address: 100 West Fourth St Waterloo IL 62298  
Street City State Zip  
Phone Number: 618-939-8600 Email Address: sdeutch@waterloo.il.us  
Not For Profit Status: Yes  No  ID # _____
  
  4. Person in Charge of Event: Tom Smith  
Mailing Address: 100 West Fourth Street Waterloo IL 62298  
Street City State Zip  
Cell Phone Number: _____ Email Address: tsmith@waterloo.il.us
  
  5. Secondary Contact Person: Sarah Deutch  
Mailing Address: 100 West Fourth Street Waterloo IL 62298  
Street City State Zip  
Cell Phone Number: _____ Email Address: sdeutch@waterloo.il.us

**THE FOLLOWING INFORMATION MUST BE PROVIDED BEFORE APPLICATION WILL BE PROCESSED.**

<b>A. Narrative of Event.</b>
PumpkinFest is a day-long fall festival including live music, games, arts & crafts/retail/business and food vendors and other entertainment. Streets need to be closed for pedestrian traffic, pumpkin train rides, hayrides, vendor booths, etc.

<b>B. Sketch Plan of Site or Route of Walk/Run</b>	Attached <input type="checkbox"/>	Not Applicable <input type="checkbox"/>
----------------------------------------------------	-----------------------------------	-----------------------------------------

<b>C. Will there be inflatable jumpers/bounce houses or amusement rides:</b> Yes <input type="checkbox"/> No <input type="checkbox"/>
• If yes, <u>Proof of Liability Insurance is required.</u> (See Clerk's Office for details.)

<b>D. Proof of Liability Insurance must be provided and, if the event is held on City property, the City of Waterloo <u>must</u> be named as an additional insured with Comprehensive General Liability limits of not less than \$1,000,000 combined single limit, each occurrence / \$2,000,000 aggregate.</b>
Attached <input type="checkbox"/>

<b>E. Liquor License information for beer sales (hours of sale):</b>
----------------------------------------------------------------------

<b>G. Special Needs (i.e. Police, Fire, EMS, Street Dept., Electric)</b>
We will request that Police and EMS be present. Electric boxes will be unlocked and the street department will need to deliver barricades at several street intersections and alleyways.

Special Event Organizer(s) must also provide for the sanitary collection of all refuse, litter, and garbage generated by patrons attending the event, and removal of all such waste materials from the location of the event in a timely manner.

<b><u>Signage</u></b>	
As part of the approval of this Special Event Permit, temporary signs for said Special Event shall be permitted as provided for in the City Sign Ordinance.	
<b>I agree to abide by the rules and certify that I, on behalf of the applicant or organization, am also authorized to commit that organization, and therefore agree to be financially responsible for any cost and fees that may be incurred by or on behalf of the event to the City of Waterloo. I also understand that acceptance of application should in no way be construed as a final approval/confirmation of this request.</b>	
_____	_____
Signature of person in charge of event	Date of Submission

*For office use only*

"Special Events Permits" shall go before the City Council for approval.

Approved by City Council: Yes  No  Date _____

Police Department <input type="checkbox"/>	Fire Department <input type="checkbox"/>	EMS <input type="checkbox"/>	Dispatch <input type="checkbox"/>
DPW / Street Department (for street closings, signalization, and detour routes) <input type="checkbox"/>			