



COMMERCIAL APPLICATION

BUILDING PERMIT, UTILITY INSTALLATION, INSPECTION & CERTIFICATE OF OCCUPANCY GUIDELINES AND REQUIREMENTS

BUILDING PERMIT GUIDELINES AND REQUIREMENTS

The following is required before your building permit application can be considered for approval:

1. Application for Building Permit and Certificate of Zoning Compliance completed in full and signed. Follow all instructions on the application and include all requested information.
2. Designation of Registered Design Professional completed in full and signed.
3. A detailed site plan of the lot is required.
4. Architectural, mechanical, plumbing, and electrical plans are required. Drawings for structures other than one- and two-family residences and their accessory buildings must be prepared, sealed, and signed by a design professional registered in the State of Illinois. The City of Waterloo has adopted the 2012 International Building Code with revisions, the National Electric Code, the National Fuel Gas Code and NFPA 54, and the Illinois State Plumbing Code. Consult Chapter 6, Building Code, of the City of Waterloo Code of Ordinances for details.
5. A copy of the recorded deed to the property and a Title Report from a title company, or an opinion letter from an attorney, verifying that the owner shown on the deed still is the owner of the subject property.
6. Application for Commercial Natural Gas Service completed in full and signed, if service is requested.
7. Application for Electric Service completed in full and signed, if service is requested.
8. Water Survey completed in full and signed.
9. Refer to the latest City of Waterloo Construction Details for installation details of all utilities.

All utility connection fees, inspection fees, and building permit fees must be paid before the building permit can be issued.

Please be aware that plumbers and roofers who work in Illinois must be licensed by the State of Illinois.

UTILITY INSTALLATION INFORMATION

- ✓ For Gas and Electric Installation, call 618.939.8600 ext. 530. Allow at least one (1) week notice.
- ✓ Don't forget to call JULIE, Illinois' One-Call System, at 811 or 1.800.892.0123 before you dig.

FIRE SUPPRESSION SYSTEMS INFORMATION

The City of Waterloo requires all utilities to be fully metered, this includes all fire suppression systems. It is the Applicants responsibility to ensure that the fire suppression system is metered. See Waterloo Construction Details Manual for water metering requirements.



INSPECTION GUIDELINES AND REQUIREMENTS

It is the responsibility of the applicant to notify the appropriate contact when work has progressed to a point where an inspection is required.

REQUIRED INSPECTIONS AND CONTACTS:

- ✓ SITE – building is staked along with lot lines - City of Waterloo Building Inspector at 618.939.8600 ext. 212.
- ✓ BUILDING* - footings; waterproofing/backfill; frame and electrical; and final occupancy- City of Waterloo Building Inspector at 618.939.8600 ext. 212 (48 hour notice required).
- ✓ INTERIOR PLUMBING * – below grade rough-in; above grade rough-in; and final occupancy - Plumbing Inspector at 618.410-4908.
- ✓ SEWER LATERAL – upon completion of tap-in but prior to covering (Must be installed as shown in City of Waterloo Construction Details.) - City of Waterloo at 618.939.8600 ext. 530. (If applicant notifies the City by 9:30 am, inspection will be same day. If applicant notifies the City after 9:30 am, inspection will be the next business day.)
- ✓ EXTERIOR PLUMBING – upon installation of water service but prior to covering** - City of Waterloo at 618.939.8600 ext. 530. (If City is notified by 9:30 am, inspection will be same day; if after 9:30 am, inspection will be the next business day.)

*For more detailed requirements, contact the City of Waterloo Building Inspector or the Plumbing Inspector.

** For details of water/fire suppression service installation, see attached "Detail Figure W-6 thru W-8" or contact the City of Waterloo at 618.939.8600 ext. 530.

CERTIFICATE OF OCCUPANCY

When the Building Official receives confirmation of final inspection approval from the Building Inspector and Plumbing Inspector and notification from the Public Works Department that water and natural gas have been approved and turned on, a Certificate of Occupancy can be obtained.

It is a violation of the City of Waterloo Ordinance to occupy or utilize any new structure for any purpose until the Building Official has issued a Certificate of Occupancy.

I have read and understand the above Building Permit Guidelines and Requirements.

Applicant



CITY OFFICES
 100 West Fourth Street
 Waterloo, Illinois 62298
 618.939.8600
 Thomas G. Smith, Mayor

**APPLICATION FOR COMMERCIAL/INDUSTRIAL BUILDING PERMIT
 AND CERTIFICATE OF ZONING COMPLIANCE**

Permit Number _____ Date _____
 Permit Issued: _____ Square Feet of Improvement: _____
 Permit Fee: _____
 Permit Denied: _____
 Cause of Denial: _____

Owner(s) Name: _____ Phone: _____
 Owner(s) Address: _____
 Applicant's Name: _____ Phone: _____
 Applicant's Address: _____

Property Interest of Applicant: () Owner () Contractor () Other
 Address of Proposed Construction: _____

Type of Commercial / Industrial Construction:
 () Principal Building () Accessory Building () Addition to Existing Structure () Other: _____

Proposed Use: _____ Total Square Feet of Proposed Construction: _____
 Does the proposed structure lie within any floodplain area? () Yes () No Zone District: _____

Does the proposed structure require fire suppression? () Yes () No See Page 1 for Special Note.

Application is hereby made for a Certificate of Zoning Compliance and Building Permit, as required under the Ordinances of the City of Waterloo, Illinois for the erection and use of buildings and premises. In making this application, the applicant represents all of the above statements and any attached maps and drawings to be a true and accurate description of the proposed new or altered uses and/or buildings. The applicant agrees that the permit applied for, if granted, is issued on the representations made herein and that any permit issued may be revoked without notice on any breach of representation or conditions. It is understood that any permit issued on this application will not grant right of privilege to erect any structure or to use any premises described for any purpose or in any manner prohibited by the City's Ordinance.

Applicant: _____
 Owner
 (if other than Applicant) _____

TEMPORARY CERTIFICATE OF ZONING COMPLIANCE

Changes in site plans or specifications **SHALL NOT** be made without written approval of the appropriate City Officials. Failure to comply with the above shall constitute a violation of the provisions of the City of Waterloo Zoning Ordinance.

 Dated

 Zoning Administrator



CITY OFFICES
100 West Fourth Street
Waterloo, Illinois 62298
618.939.8600
Thomas G. Smith, Mayor

DESIGNATION OF REGISTERED DESIGN PROFESSIONAL

Subject Property Address: _____

Owner of Property: _____

Description of Project: _____

Name of Registered Design Professional

Name: _____

Address: _____

Phone: _____

The above-named registered design professional has been requested to prepare construction documents for the above-named project and is hereby designated as the registered design professional in responsible charge, including being responsible for reviewing and coordinating submittal documents prepared by others, including phased and deferred submittal items, for compatibility with the design of the building. All documents and plans are to be submitted to

City of Waterloo Building Official
100 West Fourth Street
Waterloo, Illinois 62298
618.939.8600

Date

Property Owner

*I accept designation as the registered design professional for the above-named project
(please include stamp):*

Date

Design Professional



APPLICATION FOR COMMERCIAL NATURAL GAS SERVICE

The undersigned hereby requests that the City of Waterloo provide a gas connection at the following described property to wit:

Applicant's Name: _____

Connection Address: _____

Gas Meters: The following meters will be required at the site:

Meter	Location/Address	BTU Input
_____	_____	_____
_____	_____	_____
_____	_____	_____
_____	_____	_____
_____	_____	_____
_____	_____	_____
_____	_____	_____
_____	_____	_____

Which have a total BTU Input of _____. Applicant agrees to make a new application for any additional equipment to be added to his/her gas service after this application. The addition of equipment with total BTU Input greater than that shown herein, without the filing and approval of a new application, shall constitute cause for entire discontinuance of natural gas service by the City.

CONNECTION FEE: The City shall charge for non-residential connecting taps and for connecting taps larger than 3/4" to the gas main, the sum of Seven Hundred Forty-Nine and 00/100 Dollars (\$749.00) plus One Hundred Sixty-Seven and 35/100 Dollars (\$167.35) per each 100,000 BTUH of connected load or fraction thereof. The City shall charge, and the applicant shall pay, the cost to the City for the service line, regulator, meter, stop cock, excess flow valve and other parts, materials and items plus the cost to the City for labor, equipment use and engineering relating to the installation. The connection charge shall be paid at the time of application, and costs for installation shall be paid before gas service is commenced.

38-2-8 ALL SERVICE SHALL BE METERED (B) All gas service shall be metered with a meter of adequate size to measure the amount of gas consumed. Meters shall be of standard design and may be of the diaphragm, rotary or turbine type properly used at the discretion of the city's Public Works Director. The measurement pressure base shall be seven inches water column. The temperature base shall be 60°F.

As an inducement of the City of Waterloo to accept this applicant, the applicant:

1. Agrees to pay for all gas used on said premises at the rates provided by City Ordinance.
2. Agrees to abide by the rules and regulations of said City, and to further pay the minimum rate set by City Ordinance after gas service is available to said premises, but prior to usage by the applicant.
3. Agrees that the City assumes no responsibility for the interruption of service and the City shall have the right to discontinue service to said property for any of the following reasons:
 - a. When the safety of the general public is endangered or public convenience and necessity requires.
 - b. Defective gas services and equipment on said premises,
 - c. City maintenance and construction operations,
 - d. Violation of the City rules and regulations and/or failure to pay charges for service rendered.

All connections to the City Gas Utility Service shall be made by the City.

Connection charges must be paid in full to the City before the City commences work. In the event that additional charges become necessary because of unusual or unexpected circumstances, such charges must be paid in full to the City as soon as the work is completed. Under no circumstances will gas service be initiated until all connection charges are paid in full. Connection charges are non-refundable once work has commenced.

EASEMENT: Applicant by the execution hereof grants unto the City has the right to install and maintain the gas service line on the property to be served by said line and the right to extend along and across such property for the making of other service connections from the same gas service line.

TIME LIMITATIONS: The City will not install a gas service line more than 60 days prior to its use for service. If the gas connection is not installed and complete for service within 90 days from the date the application was granted by the City, said application shall be null and void and of no further effect.

RATE: Applicant agrees that unless he otherwise makes written request to the City, he will be billed under the provisions of Rate "General Service".

PROPERTY OWNER LIABLE: The property owner is liable, and by the execution hereof agrees, to promptly pay any delinquent charges for gas service to his tenant. The City reserves the right, and the property owner by the execution hereof agrees, to the discontinuance of gas service to said premises until said delinquent charges are paid.

RULES AND REGULATION – PART OF CONTRACT: All the rules and regulations concerning the natural gas system as approved by the City Council of the City of Waterloo are incorporated and made a part hereof and shall be binding on every gas customer and landlord.

SPECIAL NOTICES AND CONDITIONS: Any special notices and conditions of this application are shown below and are incorporated herein.



Dated at Waterloo, Illinois, this ____ day of _____, 20____.

Tenant Owner
Address Address

Application accepted by the City of Waterloo, Illinois, this ___ day of _____, 20__.

Receipt of \$_____in payment for gas connected hereby acknowledged.

Official Personnel

Account Number(s) _____

SPECIAL NOTICES AND CONDITIONS

Attention of the Applicant, Tennant and Owner is also directed to the following:

- A. All piping must be pressure tested in accordance with the latest revision of NFPA 54 to a pressure of not less than 20 psig. Said test shall be held by the Applicant or representative of Applicant until witnessed by the City gas employee responsible for initiating or restoring service.
B. Flexible connectors may not be used except as provided in the revised Municipal Code at 38-2-17 (H).
C. Unvented appliances of any type may not be used excepting kitchen ranges, clothes dryers and refrigerators as provided in the Revised Municipal Code at 38-2-17 (K).
D. Unless otherwise specially provided, every backfill at building wall or other excavation near or under a gas service line (or Main) shall be done with compacted sand to a point at least 6" above the level of the gas service line (or Main). The lateral extent of the sand backfill on each side of the service line shall be equal to the depth of the excavation. That is, for an excavation 5 feet deep, the sand backfill must extend 5 feet on each side of the service.

Sand backfill is the preferred method unless special circumstances clearly dictate another means. If a request is made to use a special bracket support, manufactured for the purpose, it must be done in writing to the Director of Public Works and subsequently approved by him in writing.



APPLICATION FOR COMMERCIAL/INDUSTRIAL ELECTRIC SERVICE

The undersigned hereby requests that the City of Waterloo provide an electrical connection to the municipal electric system at the following described property to wit:

CONNECTION ADDRESS: _____

TYPE OF CONNECTION:

COMMERCIAL/INDUSTRIAL: () NEW SERVICE () EXPANDED SERVICE
(SINGLE PHASE)

COMMERCIAL/INDUSTRIAL: () NEW SERVICE () EXPANDED SERVICE
(THREE PHASE)

REQUESTED TRANSFORMER SECONDARY SIDE AMP RATING _____ AMPS, SECONDARY VOLTAGE _____

Connection Fee: Applicant tenders herewith the sum of \$_____ in payment of the electric connection fee. As an inducement of the City of Waterloo to accept this applicant, the applicant:

1. Agrees to pay for all electricity used on said premises at the rates provided by City Ordinance.
2. Agrees to abide by the rules and regulations of said City, and to further pay the minimum rate set by City Ordinance after electric service is available to said premises, but prior to usage by the applicant.
3. Agrees that the City assumes no responsibility for the interruption of service and the City shall have the right to discontinue service to said property for any of the following reasons:
 - a. When the safety of the general public is endangered or public convenience and necessity requires,
 - b. Defective wiring and equipment on said premises,
 - c. City maintenance and construction operations,
 - d. Violation of the City rules and regulations and/or failure to pay charges for service rendered.

All connections to the City Electric Utility Service shall be made by the City.

Connection charges must be paid in full to the City before the City commences work. In the event that additional charges become necessary because of unusual or unexpected circumstances, such charges must be paid in full to the City as soon as the work is completed. Under no circumstances will electric service be initiated until all connection charges are paid in full. Connection charges are non-refundable once work has commenced.

EASEMENT: Applicant by the execution hereof grants unto the City the right to install and maintain the electric service line on the property to be served by said line and the right to extend along and across such property for the making of other service connections from the same electric service line.



LANDSCAPING: The applicant hereby agrees to re-landscape, including seeding or sodding, any areas excavated and backfilled by the City and to hold the City harmless for subsidence or sinking of any excavated area on the property.

PROPERTY OWNER LIABLE: The owner(s) of any real estate or improvements thereon, or the owner of the beneficial interest of any trust holding title to land or improvements served hereunder shall be responsible for any delinquent charges for electric service to such real estate and/or improvements.

The applicant hereby agrees that the City is under no obligation, nor can it be held liable for any damages for not serving said premises, but it is understood and agreed that the above connection fee will be refunded upon applicant's request is electric service is not available within one (1) year from this date.

We, the undersigned, by execution of this agreement, hereby agree to be bound by all the terms and conditions set forth herein. The undersigned further agrees that the installation will not be placed in operation until proper inspection has been made by the Electric Inspector of the City of Waterloo; or his representative.

Dated at Waterloo, Illinois, this ____ day of _____, 20____.

Form with fields for Renter, Phone, Property Owner, and Mailing Address, repeated twice.

Application accepted by the City of Waterloo, Illinois, this ___day of _____, 20____.

Receipt of \$_____ in payment for electric connection is hereby acknowledged.

Office Personnel

Form with fields for Rate, Account Number(s), and three blank lines.

CITY OF WATERLOO

TYPICAL SANITARY SEWER CONSTRUCTION DETAILS

EXTEND RISER TO RIGHT-OF-WAY LINE. THE RISER PIPE IS A REFERENCE POINT ONLY AND SHALL NOT BE USED AS A CLEAN-OUT. REMOVE THE RISER PIPE WHEN EXTENDING LATERAL TO BUILDING.

EXTEND LATERAL RISER MIN. OF 3' ABOVE FINAL GRADE (MUST BE CAPPED FOR PRESSURE TESTING)

2' DISTANCE VARIES (SEE PLANS)

SERVICE LATERAL & RISER: 6" MIN. DIAM.
MATERIAL: PVC PER ASTM D-3034, F-1336, AND D-1784 WITH MIN. CELL CLASSIF. OF 12454
JOINTS: ASTM D-3212, PUSH ON GASKETS: ASTM F-477
WALL THICK: SDR 26
INSTALLATION: ASTM D-2321
MIN. DEPTH OF BURY: 42"

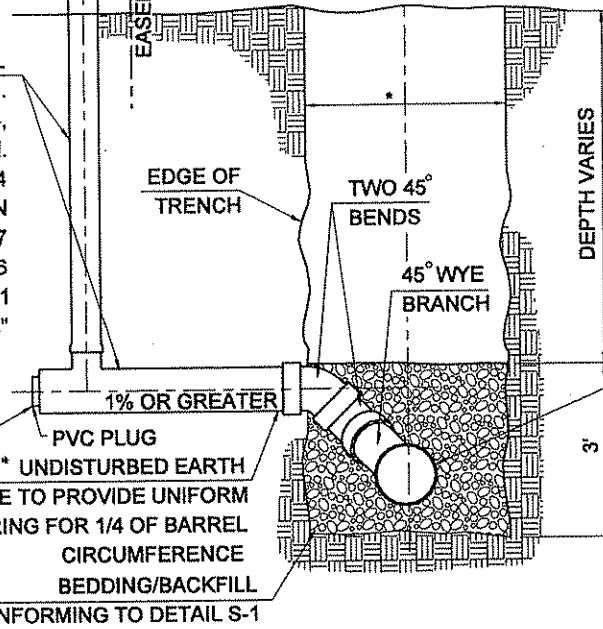

CONTRACTOR TO PLUG AIR TIGHT AND THRUST BLOCK TO ALLOW AIR TESTING OF SANIT. SEWER

PVC PLUG
* UNDISTURBED EARTH (SHAPE TO PROVIDE UNIFORM BEARING FOR 1/4 OF BARREL CIRCUMFERENCE BEDDING/BACKFILL CONFORMING TO DETAIL S-1

SANITARY MAIN: 8" MIN. DIAM
MATERIAL: PVC PER ASTM D-3034, F-1336, AND D-1784 WITH MIN. CELL CLASSIF. OF 12454.
JOINTS: ASTM D-3212, PUSH-ON GASKETS: ASTM F-477
WALL THICK: SDR 26
INSTALLATION: ASTM D-2321
MIN. BURY DEPTH OF 42"

SECTION

*UTILIZE CA-7 FOR ALL BEDDING, HAUNCHING, AND INITIAL BACKFILL AND CA-7 BACKFILL WHERE THE EDGE OF THE TRENCH IS WITHIN TWO (2) FEET OF A PERMANENT SURFACE, INCLUDING DRIVEWAYS AND SIDEWALK. USE CASE I BACKFILL FREE FROM ORGANICS AT ALL OTHER LOCATIONS

WYE BRANCH SERVICE CONNECTION:

8" x 8" x 6" PVC D-3034 MOLDED SADDLE TEE-45 DEG. WYES W/GASKETED BRANCH CONFORMING TO ASTM 679 AND SOLVENT WELDED SKIRTS HELD IN PLACE W/WALL STAINLESS STEEL ADJUSTABLE BAND CLAMPS. W/MAIN MATERIAL OTHER THAN PVC, USE MECHANICALLY CUT HOLES AND SADDLES AS ABOVE, EXCEPT A NON-HARDENING GASKET, SILICONE CAULKED IN PLACE SHALL BE USED.

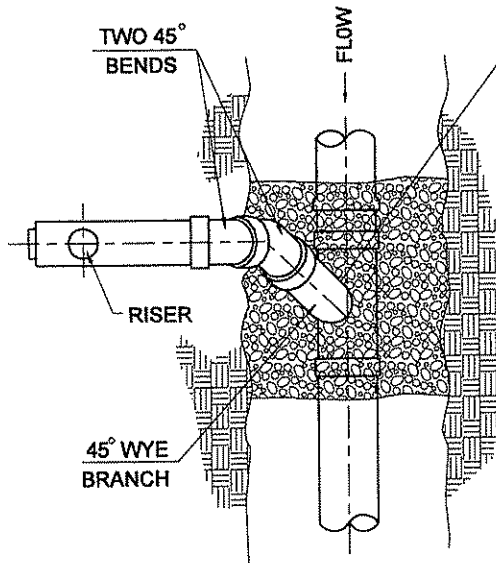

PLAN

SANITARY SEWER & SERVICE CONNECTION DETAIL

DETAIL S-3

CADD FILE: server\3223\2008-Construction\Details\S-3.dgn

CITY OF WATERLOO

TYPICAL WATER MAIN CONSTRUCTION DETAILS

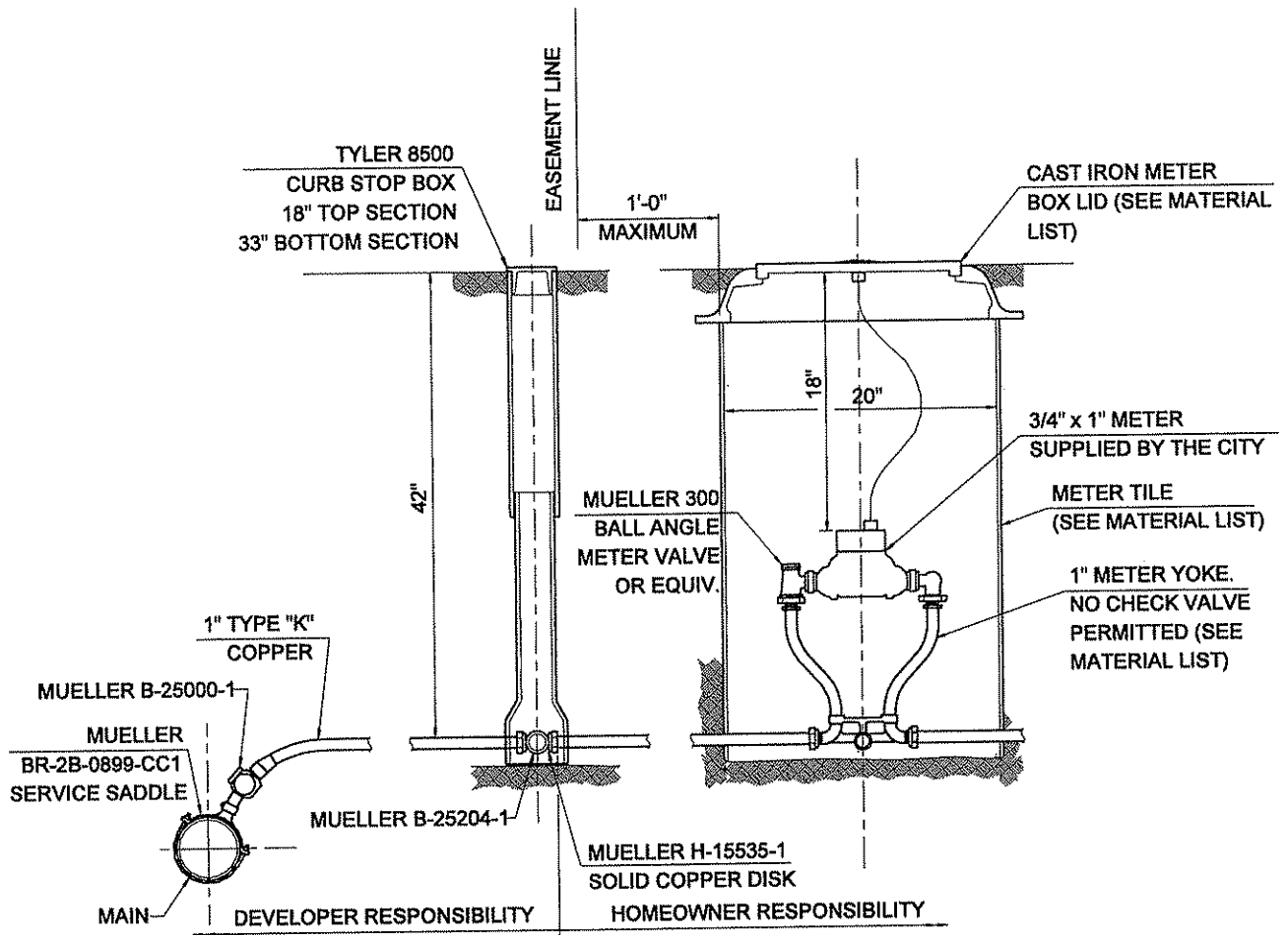

SINGLE METER PIT INSTALLATION

QTY.	ITEM#	DESCRIPTION
1	H10810-09	20 x 11 SINGLE HOLE TOUCH READ LID ASSY. LARGE NUT (MUELLER)
1		20 x 36 MID STATES PLASTIC METER TILE
1	B2404 (1")	1" x 12" METER YOKE WITH BALL VALVE
2	H14222 (1")	1" TP & NUT

DOUBLE METER PIT INSTALLATION

QTY.	ITEM#	DESCRIPTION
1	H10810-10	20 x 11 SINGLE HOLE TOUCH READ LID ASSY. LARGE NUT (MUELLER)
1		24 x 36 MID STATES PLASTIC METER TILE
1		24 x 20 ADAPTER RING
1	B2404 (1")	1" x 12" METER YOKE WITH BALL VALVE
2	H14222 (1")	1" TP & NUT

NOTES:

1. WATER METERS SHALL BE 3/4" x 1" SENSUS SR TRPL 100 GALLON, 4WHL 5B, ROCKSYN CHAMBER CAST IRON BOTTOM, 6' SENSOR, & TBH PKG.
2. THE CITY OF WATERLOO USES MUELLER PRODUCTS AND CAN NOT ACCEPT SUBSTITUTIONS.
3. 3/4" WATER METERS WITH TOUCH READ WILL BE SUPPLIED AFTER THE PIT IS INSTALLED AND INSPECTED BY THE CITY.
4. WATER METERS WITH TOUCH READ LARGER THAN 3/4" SHALL BE SUPPLIED BY THE BUILDER OR CONTRACTOR AT HIS EXPENSE.

**RESIDENTIAL
WATER SERVICE
INSTALLATION
TYPICAL PRESSURES**

DETAIL W-6

CADD FILE: server\3223\2009-ConstructionDetails\WATSTD4.dgn

CITY OF WATERLOO

TYPICAL WATER MAIN CONSTRUCTION DETAILS

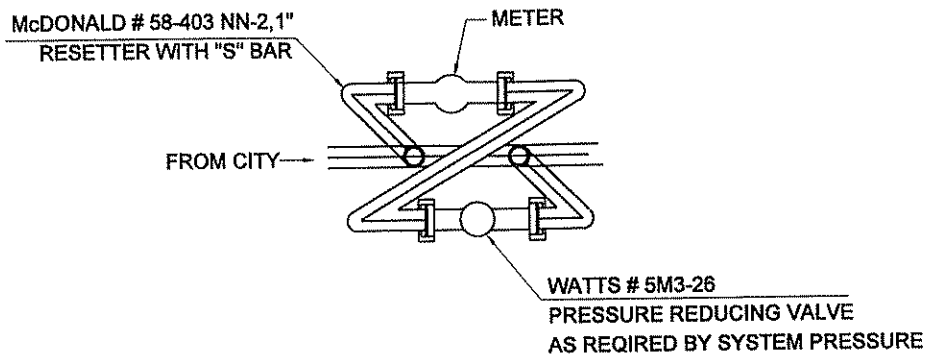

RESETER/PRV DETAIL

NOTE: HOMEOWNER TO PROVIDE AND INSTALL
RESETER AND PRESSURE REDUCING VALVE (PRV)
PROPERTY OWNER MAY INSTALL VALVE ASSEMBLY
INSIDE HOUSE OR INSIDE METER PIT.

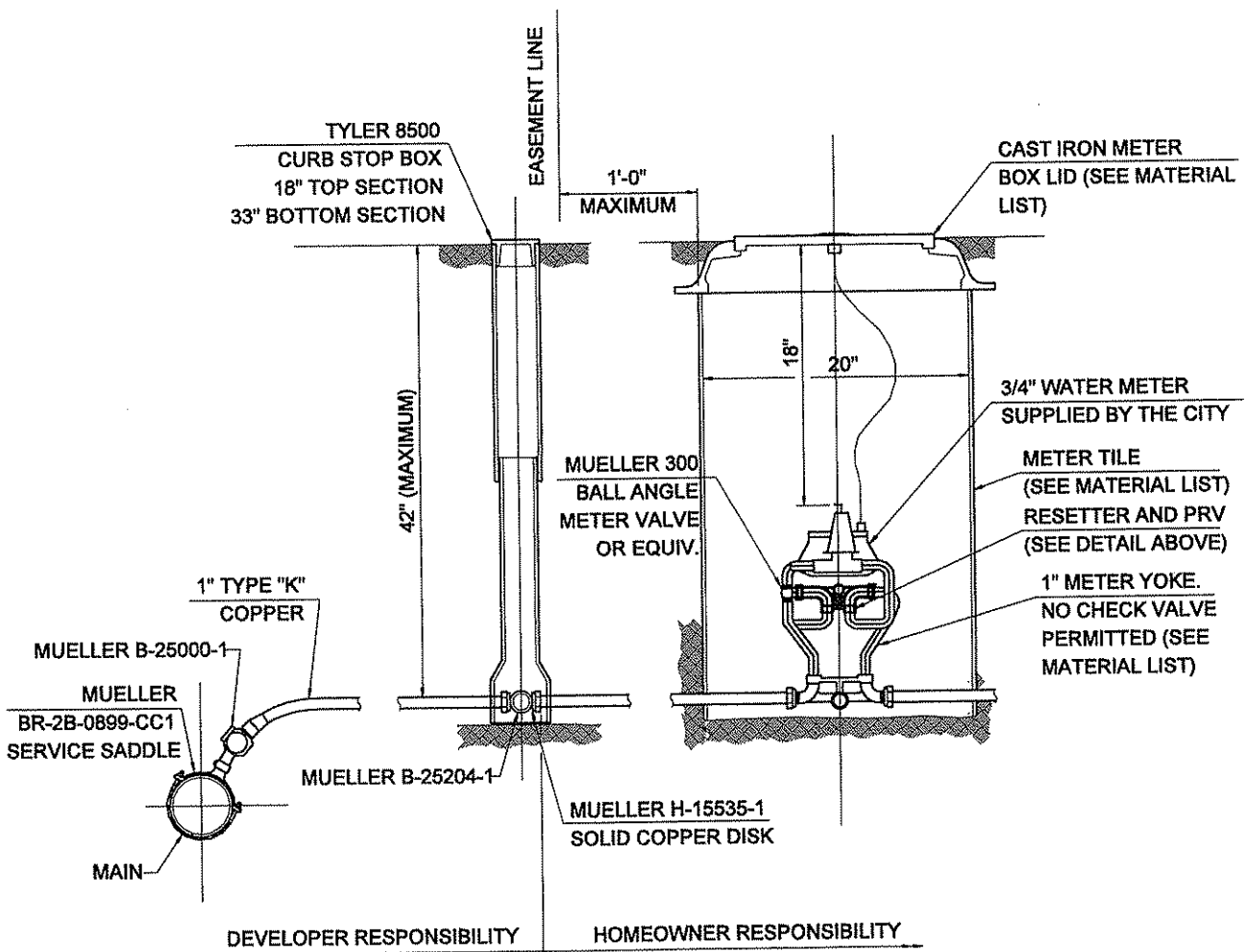

NOTES:

1. WATER METERS SHALL BE 3/4" x 1" SENSUS SR TRPL 100 GALLON, 4WHL 5B, ROCKSYN CHAMBER CAST IRON BOTTOM, 6" SENSOR, & TBH PKG.

**RESIDENTIAL
WATER SERVICE
INSTALLATION
HIGH PRESSURES**

DETAIL W-7

CADD FILE: server\323\2009-ConstructionDetails\W-7.dgn

CITY OF WATERLOO

TYPICAL WATER MAIN CONSTRUCTION DETAILS

RESIDENTIAL AND COMMERCIAL WATER SERVICE INSTALLATION

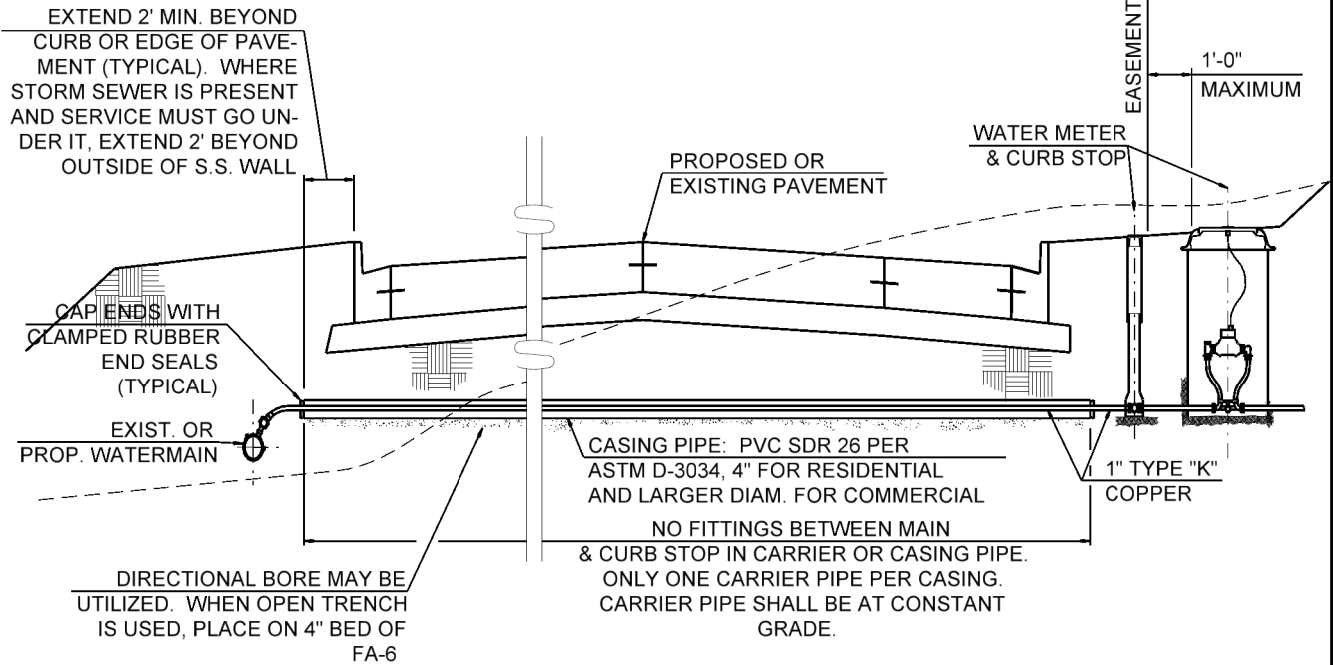

TYPICAL COMMERCIAL INSTALLATION

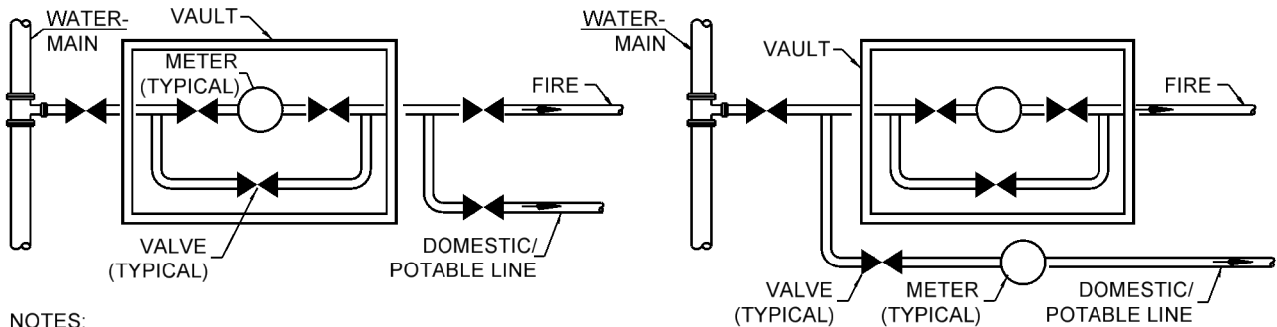

NOTES:

1. DUE TO NATURE OF COMMERCIAL SERVICES, THE DESIGN OF COMMERCIAL INSTALLATIONS SHALL BE APPROVED ON AN INDIVIDUAL BASIS BY THE DIRECTOR OF PUBLIC WORKS.
2. FOR FACILITIES SUCH AS IRRIGATION, SWIMMING POOLS, BOOSTER PUMPS, AND COMMERCIAL INSTALLATIONS, SEE CITY WATER CODE, CHAPTER 38 FOR BACKFLOW PREVENTION REQUIREMENTS.
3. ALL COMMERCIAL WATER METERS SHALL BE SENSUS TOUCH READ METERS. DOMESTIC METERS SHALL BE iPERL FOR 1" AND SMALLER SERVICES AND OMNI C2 FOR 1" AND LARGER SERVICES. FIRE METERS SHALL BE OMNI C2.
4. IF OWNER WISHES TO INSTALL METERS IN BUILDING, 1" THRU WALL CONDUIT SHALL BE INSTALLED FOR INSTALLATION OF TOUCH READ ASSEMBLIES, TO THE FACE OF THE BUILDING.
5. TOUCH READ ASSEMBLIES SHALL BE INSTALLED ON THE LID OF THE VAULT, THE LID OF THE METER PIT, OR THE FACE OF THE BUILDING. LOCATION MUST BE APPROVED BY THE CITY PRIOR TO INSTALLATION.
6. ALL INSTALLATIONS SHALL MEET ILLINOIS PLUMBING CODE.

WATER SERVICE INSTALLATIONS

DETAIL W-8