



CITY OFFICES
100 West Fourth Street
Waterloo, Illinois 62298
(618) 939-8600
Stanley T. Darter, Mayor

DATE OF APPLICATION: _____

Zoning Administrator
(618) 939-8763

CITY PERMIT No. : _____

APPLICATION FOR EXCAVATION PERMIT

Each address and/or street segment requires a separate excavation permit. Work occurring at multiple addresses or on multiple streets shall require individual permits for each location.

Name of Applicant Mailing Address

_____ hereinafter referred to as the Permittee,
State and Zip

requests permission and authority to occupy, and to do certain work herein described, on, across, or along the City street, easement, alley, right-of-way or roadway known as _____ from _____ to _____ in the City of Waterloo, Monroe County, Illinois. The work is described in detail below and/or on the attached sketch or plans

No permit shall be issued unless and until the permittee has deposited with the Clerk a Performance Guarantee as outlined in the Revised Code of Ordinances, Section 33-4-5 to ensure the permittee makes the proper restoration of the ground laying of the pavement. The required Certificate of Insurance must list the City of Waterloo as an additional insured and must also be filed with and acknowledged by the Zoning Administrator.

The work to be authorized by this permit shall be completed within 14 days after the date of approval by the Director of Public Works of the City of Waterloo, otherwise the permittee will forfeit the Performance Guarantee.

This permit covers the operation and presence of specified equipment, material or facility on the right-of-way which may be related to the authorized work.

If granted, this permit is subject to the conditions and restrictions set forth in Chapter 33, Article IV, which the permittee states he has read and agrees to comply with all of its contents.



_____	_____
Name of Contractor	Mailing Address
_____	_____
Phone Number	City, State, Zip
_____	_____
Signature of Permittee	Mailing Address
_____	_____
Date	City, State, Zip

CITY OF WATERLOO

Guarantee, insurance or waiver of requirement is acknowledged. This permit allowing occupancy and work on the City street or roadway is hereby approved on this:

_____ day of _____, 20 _____

By: _____ By: _____
Zoning Administrator Director of Public Works



INSURANCE REQUIREMENTS

07-06-11

Requirements:

1. Successful bidders on Contract work shall furnish the City a Performance Bond and Payment Bond for 100% of the contract amount and provide Certificates of Insurance that verifies the contractor has insurance that meets the following minimum requirements:

a.	Workers' Compensation	Statutory
b.	Employers Liability	\$1,000,000.
c.	General Liability - per occurrence	\$1,000,000.
	- general aggregate	\$3,000,000.
d.	Auto Liability	\$1,000,000.

All Certificates of Insurance shall verify the City of Waterloo has been named as an additional insured under the contractor's general liability policy. In addition, the contractor shall also file a Surety Bond for the guarantee of the work for a period of one (1) year after the date of acceptance of the work. A Waiver of Subrogation in favor of the City of Waterloo should be provided on Workers' Compensation, General Liability and Auto Liability policies.

NOTES:

- a. The City of Waterloo also requires a 100% Performance Bond and a 100% Payment Bond; and
 - b. The City of Waterloo also requires a \$1,000,000. Umbrella Coverage, and when applicable, Builders Risk Insurance for at least the value of the contract; and
 - c. In addition, the City may require additional Hazard Insurance for the project.
2. All other service providers shall provide the City of Waterloo with a Performance Guarantee in the amount of \$10,000.00 in the form of cash, Letter of Credit from a bank doing business in the State of Illinois, or a Certificate of Deposit.

In addition, said service providers shall provide the City of Waterloo with a Certificate of Insurance verifying minimum coverage as follows:

a.	General Liability - per occurrence	\$1,000,000.
	- general aggregate	\$3,000,000.
b.	Auto Liability*	\$1,000,000.
c.	Workers' Compensation	Statutory.
d.	Employers Liability	\$1,000,000.
e.	Professional Liability**	\$1,000,000.

* May be waived by Mayor, Director of Public Works or the Budget Director if autos are not used by the service provider to fulfill the service provided.

** Applies when professional services are being rendered such as legal, accounting, tax, insurance or engineering.

All Certificates of Insurance shall verify the City of Waterloo has been included as an additional insured under the service provider's general liability and professional liability policies.

EXCAVATION AND DEMOLITION PERMITS

Chapter 33 – Street Regulations Article IV – Excavations and Underground Damage Prevention

1. Excavation Permits are only required for work that will encroach on a city easement or right-of-way.
2. Proposed work shall be staked out before approval of permit.
2. The fee for an Excavation Permit is \$75.00. The fee for a Demolition Permit is \$175.00.
3. The License Bond, Permit Bond, Performance Bond or Performance Guarantee is essentially the same thing.
 - a. 34-4-5 Performance Guarantee – requires a \$1,000.00 “bond”. Companies performing house drops shall provide a \$1,000.00 bond. Other contractors are held to the \$10,000.00 bond when working in an easement and/or right-of-way where utilities are located and the damage may be significant.
 - b. “Bond” can be 1) cash, 2) letter of credit, or 3) certificate of deposit.
4. 33-4-6 Liability Insurance
 - a. The General Aggregate of \$3 million can be satisfied by a combination of \$2,000,00.00 “general aggregate” and an additional \$1,000,000.00 “excess/umbrella liability”.
 - b. The workers comp. lines on the Certificate of Insurance shall show a minimum of \$500,000.00.
5. Utility Termination
 - a. The city is responsible for terminating the gas service at the main and the electric service at the pole or the transformer box.
 - b. The contractor is responsible for terminating and capping the water and sewer services at the mains. Additionally, the finished work must be inspected by the utility departments before covering the lines back up.
6. Demolitions Only
 - a. The Building Inspector does an inspection of the building foundation and/or basement floor.
7. A Demolition Permit cannot be issued until the Electric Department and Underground Utility Department have issued a written memo saying the utilities have been properly terminated, by their respective departments.

§ 33-4-5 PERFORMANCE GUARANTEE.

- (A) No permit for any work, construction, demolition or excavation on city-owned property shall be issued by the city unless the person applying therefor or the contractor shall have filed with the Zoning Administrator a performance guarantee. Said guarantee shall be a minimum of \$1,000. When, in the opinion of the Public Works Director, the excavation is sufficiently hazardous to require a higher guarantee, a maximum of \$10,000 is therefore required. Said guarantee shall be in the form of cash, letter of credit from a bank doing business in the State of Illinois, or certificate of deposit. If, in the opinion of the Public Works Director, an excavation requires a performance guarantee more than \$10,000, it first must be approved by the City Council before a permit can be issued.

- (B) Said performance guarantee shall be received by the Zoning Administrator, conditioned upon the applicant or contractors completing the excavation, drilling, boring, construction or excavation in a proper and workmanlike manner and indemnifying and saving the city harmless for any and all damage to any property of the applicant or to the property of the city or the property of any third party from failure to restore any road, ditch, easement, pavement or portion thereof damaged during the construction, demolition or excavation so as to ensure that such property of the city or such property of the applicant, together with such road, ditch, easement, pavement or portion thereof damaged are left in as good condition as the applicant or contractor found them. Only the City Council may waive the performance guarantee.

§ 33-4-6 LIABILITY INSURANCE.

No permit for excavation, drilling, boring, construction or demolition shall be issued by the city or its authorized representatives unless the person applying therefor or the contractor shall have first procured insurance which meets the minimum insurance requirements outlined below. When in the opinion of the Mayor, Director of Public Works or the Budget Director, the service being provided is sufficiently hazardous to require higher requirements, they may require higher limits and/or requirements than those indicated as follows: Applicants shall furnish the city with certificates of insurance that verify the contractor has insurance that meets the following minimum requirements and names the city as an additional insured:

- | | | |
|-----|-----------------------|-------------|
| (A) | Workers' Compensation | Statutory |
| (B) | Employers Liability | \$1,000,000 |
| (C) | General Liability: | |
| | (1) Per occurrence | \$1,000,000 |
| | (2) General aggregate | \$3,000,000 |
| (D) | Auto Liability | \$1,000,000 |

CITY OF WATERLOO

TYPICAL UTILITY CONSTRUCTION DETAILS

UTILITY, SANITARY SEWER, AND WATER MAIN PATCHING DETAILS FOR TRENCHING

SEE OTHER TRENCHING DETAILS FOR UTILITY (ELECTRIC, GAS, ETC.), SANITARY SEWER, WATER MAINS, AND STORM SEWERS. NOTED TRENCHING DETAILS TO BE USED IN ASSOCIATION WITH PATCHING DETAILS, AS REQUIRED

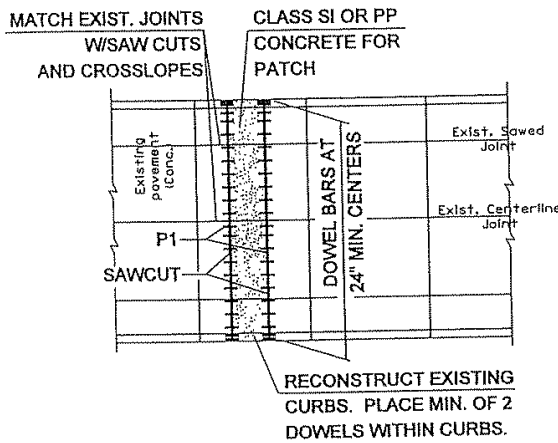

DETAILS FOR CONCRETE PAVEMENT

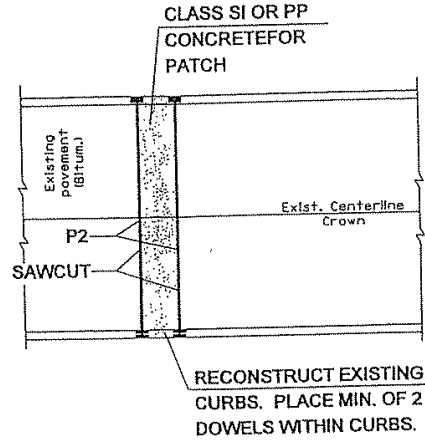

DETAILS FOR BITUMINOUS PAVEMENT

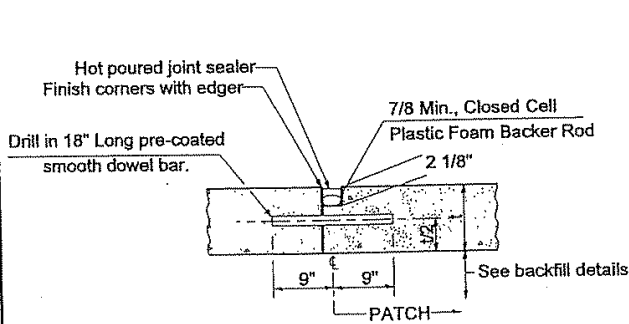

P1-PATCHING TRANSVERSE JOINT

CONCRETE THICKNESS	DOWEL BAR DIAMETER
All thicknesses	1"

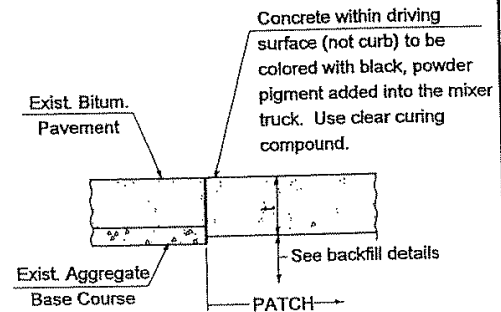

P2-PATCHING TRANSVERSE JOINT

$t = 7"$ (Min.), or as required by pavement design

CAAD FILE: sewer/3223/2009-ConstructionDetails/U-2.dgn

DETAIL SS-1A

CITY OF WATERLOO

TYPICAL STORM SEWER CONSTRUCTION DETAILS

NON-PAVED AREAS TRENCHING DETAILS

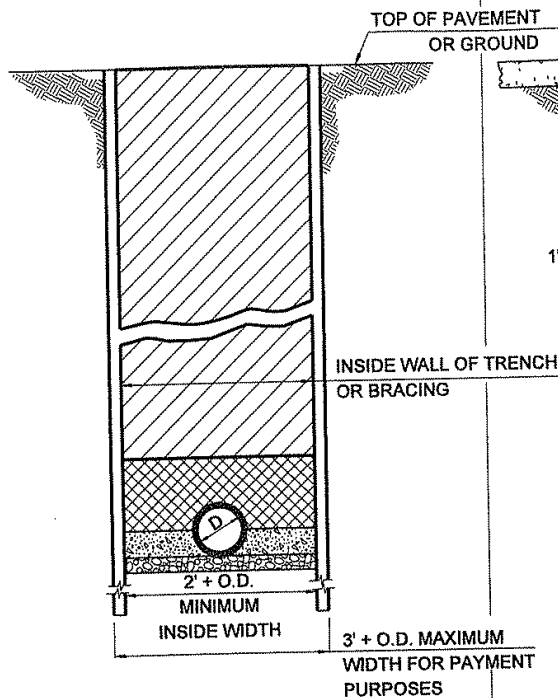

PAVED AREAS TRENCHING DETAILS

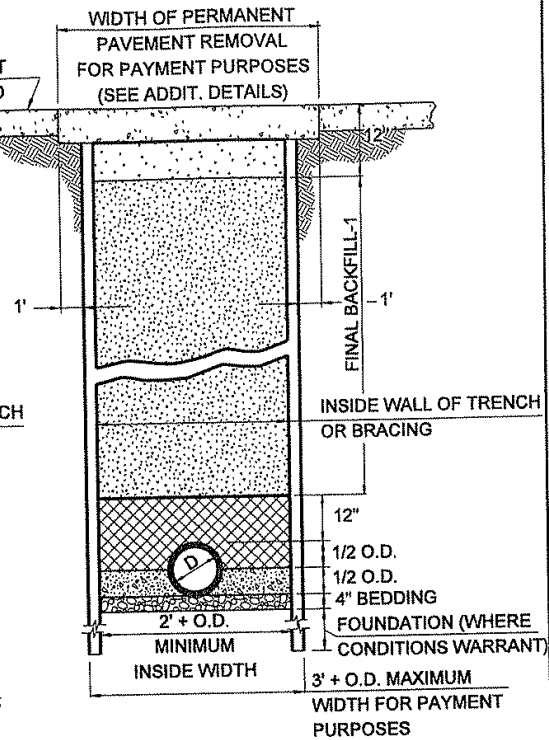

BEDDING

 CA-7, ALL LOCATIONS
(INCIDENTAL TO THE COST OF PIPE)

HAUNCHING

 CA-7, ALL LOCATIONS
(INCIDENTAL TO THE COST OF PIPE)

INITIAL BACKFILL

 APPROVED PLASTIC PIPE
CA-7, ALL LOCATIONS
(INCIDENTAL TO THE COST OF PIPE)
REINFORCED CONCRETE PIPE
CASE I BACKFILL

FINAL BACKFILL

 CASE I BACKFILL

ALL CASE I BACKFILL SHALL BE EXCAVATED
MATERIAL FREE OF ORGANICS, CLODS, ETC.

BEDDING

 CA-7, ALL LOCATIONS
(INCIDENTAL TO THE COST OF PIPE)

HAUNCHING

 CA-7, ALL LOCATIONS
(INCIDENTAL TO THE COST OF PIPE)

INITIAL BACKFILL

 CA-7, ALL LOCATIONS
(INCIDENTAL TO THE COST OF PIPE)

FINAL BACKFILL-1

 CA-7 (TYPE A), ALL LOCATIONS WHERE THE EDGE
OF THE TRENCH IS LOCATED WITHIN TWO (2) FT.
OF A PERMANENT SURFACE, INCLUDING DRIVE-
WAYS AND SIDEWALK (PAID FOR SEPARATELY).

FINAL BACKFILL-2

 CA-8 (TYPE A), ALL LOCATIONS AS DESCRIBED
FOR FINAL BACKFILL-1.

CADD FILE: sewer/2223/2009-ConstructionDetails/SS-1.dgn

DETAIL SS-1